

MODELS 510 & 511 ROOM-TO-ROOM FANS

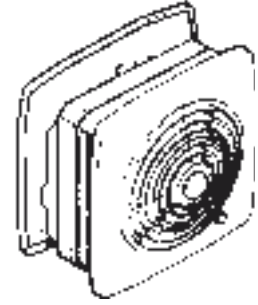

Easily installs in interior walls to move heated or cooled air from one room to another. Spreads heat from fireplaces, cool air from air conditioners to adjoining rooms.

FEATURES

GRILLE:

- Two contemporary styled grilles complement modern decor
- White polymeric grilles can be painted to match any decor

MOTOR:

- Permanently lubricated, thermally protected, plug-in motor
- Motor assembly offers fast, easy "twist-lock" installation
- Solid state speed control for fan speed and sound level selection

HOUSING:

- Requires 11-5/8" square hole through both interior walls
- Housing can be fastened to walls in several ways – allows flexibility to meet almost any mounting situation
- Adjustable housing fits walls from 3" to 5½" thick
- Housing 25 gage finished with rugged black electrically-bonded epoxy paint

TYPICAL SPECIFICATION

Ventilator shall be Broan Model 510 (Model 511).

Ventilator shall be installed in an interior wall 3" to 5½" thick — NOT through a fire-rated wall.

Ventilator shall be steel housing finished with electrically-bonded epoxy paint. Grille to be white polymeric.

Motor assembly shall be removable and permanently lubricated. RPM shall not exceed 1550 (Model 510), 1575 (Model 511).

Air delivery shall be no less than 380 CFM and sound level no greater than 6.5 Sones (Model 510), 180 CFM and 3.5 Sones (Model 511). All air and sound ratings shall be certified by HVI. Units shall be U.L. listed.

SPECIFICATIONS

| MODEL | VOLTS | AMPS | RPM | SONES | CFM |
|-------|-------|------|------|-------|-----|
| 510 | 120 | 1.7 | 1550 | 6.5 | 380 |
| 511 | 120 | 0.9 | 1575 | 3.5 | 180 |

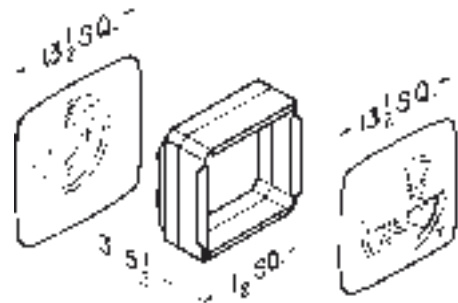

HVI-2100 CERTIFIED RATINGS comply with new testing technologies and procedures prescribed by the Home Ventilating Institute, for off-the-shelf products, as they are available to consumers. Product performance is rated at 0.1 in. static pressure, based on tests conducted in AMCA's state-of-the-art test laboratory. Sones are a measure of humanly-perceived loudness, based on laboratory measurements.



Broan-NuTone LLC, 926 West State Street, Hartford, WI 53027 (1-800-637-1453)

| REFERENCE | QTY. | REMARKS | Project |
|-----------|------|---------|------------------------------------------------------|
| | | | Location |
| | | | Architect |
| | | | Engineer |
| | | | Contractor |
| | | | Submitted by Date |