

INSTALLATION INSTRUCTIONS

CARE AND USE MANUAL FOR:

SIU 404 ISLAND RANGE HOODS



*** BEFORE INSTALLATION ***
ENSURE THERE IS NO VISIBLE OR HIDDEN DAMAGE SUSTAINED
DURING SHIPPING

*** SHIPPING DAMAGE ***
MUST BE REPORTED WITHIN 5 DAYS OF RECEIPT

WARNING

*Thank you for purchasing a Sirius Range Hood.
Please read all the instructions in this manual
before installing the appliance.*

Save these instructions for future reference.

Only use this appliance as an exhaust ventilation system for the removal of cooking vapors. **DO NOT** use to expel flammable substances or any other materials or vapors.

The installation procedures in this manual are intended for qualified installers, service technicians or persons with similar qualified background. **DO NOT** attempt to install this appliance yourself.

Ensure that electrical power is turned off at source before commencing installation. All electrical wiring must be properly installed, insulated and grounded and conform to all applicable codes and standards.

Make sure all existing duct work is clean of grease build up, or duct work should be replaced, if necessary, to avoid the possibility of a grease fire. Check all joints on ductwork to ensure proper connection and all joints should be properly taped. Be careful when cutting through ceilings or walls not to damage any hidden pipes or electrical wiring. Ensure your kitchen has sufficient air return vents to replace the exhausted air.

Fan ducts should always be vented to the outside of your home and never into spaces within walls, ceilings, lofts or attics. Only use rigid, smooth steel for ducting. The exhaust point of the blower requires a 6" round connection.

TABLE OF CONTENTS

BEFORE YOU BEGIN	1
MINIMUM AND MAXIMUMS	1
DUCTING	1
Duct Run Calculation	2
ELECTRICAL	2
Electrical Supply	2
INSTALLATION	2
Structural preparation for the hood fan installation	2
Fixing the Main Support Bracket	3
Attaching the range hood to the ceiling	4
Connecting Electricity and Ducting	4
Re-Circulating Requirements	5
Schematic of Classical Island Components	5
OPERATING PROCEDURES	6
General Advice	6
Functions	6
MAINTENANCE	7
Cleaning the Filter	7
Cleaning the Hood	7
Light Bulb Replacement	7
WARRANTY	8

BEFORE YOU BEGIN

The manufacturer declines all responsibility in the event of failure to observe the instructions given here for installation, maintenance and suitable operation of the product. The manufacturer further declines all responsibility for injury due to negligence and the warranty of the unit automatically expires due to improper maintenance and/or installation.

BEFORE YOU BEGIN:
It is advisable to test run the range hood before installation.

BEFORE STARTING – please read this entire document and ensure you are fully conversant with the requirements and limitations. These units weigh approximately 125lbs and therefore require a minimum of two people to install.

MINIMUM AND MAXIMUMS

Min length of power unit structure with deflector connected = 36.6"
Min length of power unit without deflector = 32"
Max length of power unit structure = 48"
Recommended height from cook top to underside of hood = 30" for gas
25" for electric

DUCTING

If vented externally, 6" / 150mm round ducting must be available for the hood through the ceiling, in line with the central vertical axis of the range hood.

This unit must have it's own ductwork. Do not under any circumstances vent this unit into any other ductwork or exhaust ducting in the building.

PLEASE NOTE THAT THE DUCT OUTLET ON THE TOP OF THE POWER UNIT IS OFF SET FROM CENTRE AND THEREFORE AN ADJUSTABLE 6" ROUND BEND WILL BE REQUIRED TO LINE THE

EXHAUST OUTLET WITH THE 6" HOLE IN THE CEILING MOUNT BRACKET.

Use the shortest most direct ductwork route possible. Only use metal ducting - plastic ducting is generally not permitted by code. Do not use flexible metal ducting as the ridges of the ducting cause severe air turbulence and will significantly reduce the efficiency of any hood - THIS TYPE OF DUCTING WILL REDUCE EFFICIENCY BY 50%.

Vent hoods may interrupt the proper flow of exhaust gases from fireplaces, gas furnaces and gas water

heaters. To minimize the risk of drawing these lethal gases back into the home please follow the heating equipment manufacturers safety standards and guidelines. Refer to NFPA and ASHRAE for additional information.

Duct Run Calculation

The maximum duct run before effecting the performance of the hood is 100'. Calculate your duct run by measuring linear feet and adding the elbows, transitions and caps

based on the table below.

Maximum Run	
6" or 3 1/4 x 10" duct	100 FT
Deduct	
Each 90 elbow used	15FT
Each 45 elbow used	9FT
Each 6" or 3 1/4 x 10" duct	
Transition used	1FT
Each 3 1/4 x 10" to 6"	
Transition used	5FT
Side Wall with damper	30FT
Roof Cap	30FT

ELECTRICAL

WARNING: All electrical work must be performed by a qualified electrician.

Please ensure that the appropriate electrical codes or prevailing local building codes and ordinances are adhered to.

Ensure that the electricity supply is disconnected at source. Do not use an extension cord or adapter plug with this appliance.

This appliance must be grounded. Connect to a properly grounded branch circuit, protected by a 15 amp circuit breaker.

Electrical Supply

This appliance requires 120V/60Hz, 3amp electrical supply – ensure an appropriately qualified person completes the electrical hook-up. The connection point for the electrical supply is at the top of the unit, therefore the electrical supply must be run down from the ceiling alongside the ductwork.

All electrical and venting hook-ups must be in place before commencing installation of the hood-fan.

INSTALLATION

Structural Preparation for the Hood Fan Installation

The island hood weighs approximately 125 lbs. It is therefore imperative that a substantial structure is prepared in the ceiling to attach the range hood to. Ideally block off

an area of at least 12"x12" between the ceiling joists using 2x4's. Allow for a hole through the center of this blocking of at least 6" in diameter through which to pass the ductwork and electrical cable.

The underside of the hood must not be closer than 30" from the cook-top

and ideally not higher than 32" above the cook-top. It is strongly recommended, at this point, that calculations and measurements be made and all planning and heights be finalized. You will need to fit the appropriate length of ducting to the hood fan before installing it to the ceiling.

Planning should consist of a test assembly of the power unit and telescoping structure before attempting to mount everything to the ceiling. By following this test assembly you will be able to finalize the correct length of the assembly before mounting it to the ceiling.

Test assembly should include actually attaching the following items together – refer schematic of components and **"Fixing the main support brackets"** below – Brackets A, B, C, power unit and deflector if re-circulating.

This is also a good time to test the electrical functioning of the hood before it is installed. Before switching on the light or lights, ensure the tape holding the globes in place has been removed. The globes get extremely hot and will very quickly burn the tape and discolor the globes irreparably.

Do not switch on the lights with the hood flat on any surface as the intense heat will burn the surface and destroy the lamps. Connect a power supply to the unit and test all functions.

Installation of the island hood consists of fixing the ceiling Bracket A **substantial** members in the ceiling. The bracket must be fixed to

the frame by screwing through the ceiling into the heavy members inside the ceiling. **This is critically important as the entire hood fan hangs from this position, and ceiling board alone will not support the weight of the hood fan.** Discard the plastic wall plugs supplied for fixing the bracket to the ceiling – these are not appropriate for North American structures.

Fixing the Main Support Brackets

If the range hood will be fixed to drywall we strongly recommend that you discard the wall plugs and screws supplied. These anchors are only suitable for brick/masonry applications. We suggest the use of a more appropriate anchor system specifically designed for drywall

Using Bracket "A" as a template mark the ceiling where the fixing screws "A" will be positioned – **remember the correct orientation from above.** Attach bracket "A" to the ceiling permanently. If re-circulating, attach the deflector to Bracket "A" before fixing it to the ceiling – refer schematic on page 5.

The 2 brackets for the support of the chimney (Part A) is to be installed to Bracket A with the screws (C Figure.1) Fix the structure on the ceiling by inserting the 2 dowels

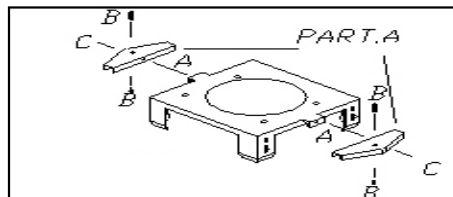

Figure 1

Fix Bracket "C" to the power unit with the nuts and washers supplied (Items "A" on the schematic on page 5). Please ensure that the bracket is installed as shown to enable full access to the square plastic black box and the metal electrical junction box. Slide Bracket "B" over Bracket "C" (once again ensure full access to the plastic and electrical boxes is maintained) and fix it in place, at the previously calculated length using the machine screws denoted by items "B" on the schematic on page 5.

Check that the plastic flaps at the exhaust outlet for the fan move freely and have not become jammed during shipping or whilst working with the power unit. Connect an appropriate length of ducting to the unit.

Do not fix the ducting to the outlet with screws - use **DUCT TAPE**.

Stand the assembled structure on a clean soft surface. Ensure the underside of the hood does not get scratched and slide the chimneys of the assembled structure from the top down as per the schematic on page 5. Ensure that the holes for fixing the decorative chimney are correctly orientated with the holes at the top of bracket "A".

Attaching the Range Hood to the Ceiling

The entire structure that has been pre-assembled above, must now be hoisted up to the ceiling. A few things have to happen at once here: the slots (as discussed below) need to be engaged and the ductwork must make connection with the length of ductwork on the structure.

This will require two strong people – do not attempt this step on your own. Bracket "B" has slots, position C per Diagram "A" (refer to page 5), at the top that will receive the spring clips located on Bracket "A" – THIS IS A TEMPORARY HOLD ONLY –

DO NOT RELY SOLELY ON THESE CLIPS TO HOLD THE HOOD UP – THEY WON'T. Once "hooked" by the spring clips immediately secure the structure with the machine screws at point "E" on the schematic on page 5 – THIS MUST BE DONE IMMEDIATELY AND SHOULD NOT BE SKIPPED.

Ensure the entire structure is sturdy - serious injury, death and MAJOR damage could result should the unit not be well connected to the frame structure within the ceiling.

This is of utmost importance – do not go any further until this has been tested and double checked – the installer has sole responsibility for the safe installation of this product.

Connecting Electricity and Ducting

Make sure power is turned off at the source. Make the electrical connection (see figure 2). Test the functioning of the hood. Slide the upper chimney into place and attach with the machine screws provided to Bracket "A".

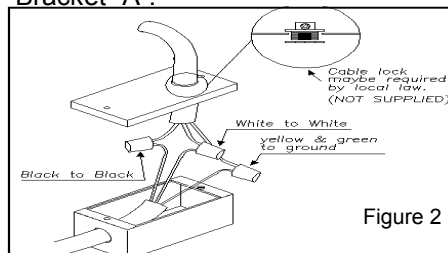

Re-Circulating Requirements

Fit the carbon filter after the installation is complete – these fit in behind the aluminum grease filter.

A short length of ductwork must be connected from the exhaust outlet

up to the deflector (must be purchased with hood).

The deflector, after attaching part B with screws E connects to the top of Bracket "A" and forces the air out through the grills on the side of the chimney section back into the room. (see diagram C).

SCHEMATIC OF MODULAR ISLAND COMPONENTS

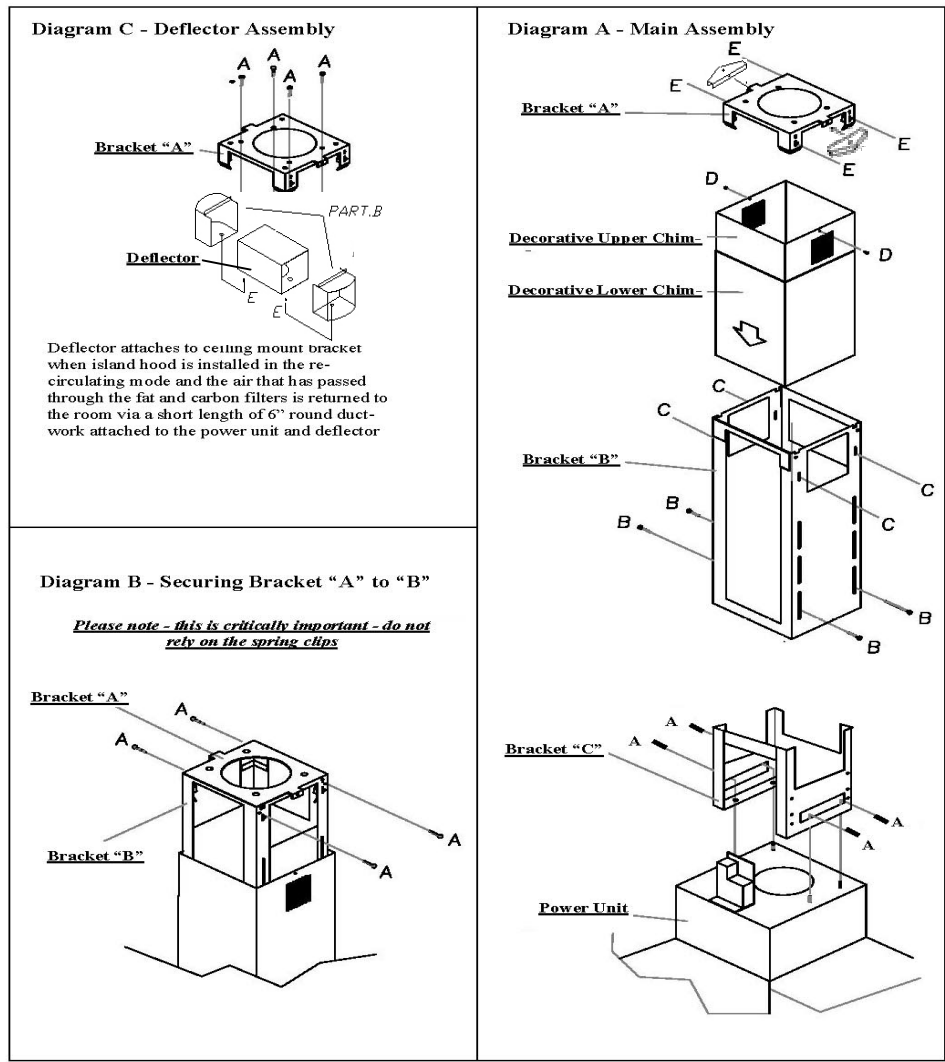

OPERATING PROCEDURES

Read all the instructions before operating the appliance. Save these instructions for future reference.

General Advice

Ensure that the grease filters are in place. Without these components, operating blowers could catch on to hair, fingers and loose clothing. Keep fan, filters and surfaces clean of grease and fat. Always turn hood fan ON when cooking. NEVER leave cooking unattended.

NEVER dispose cigarette ashes, ignitable substances or any foreign objects into blowers.

Cooking that generates flame is not recommended as this hood is equipped with a thermal overload that will shut down the motor if it senses excessive heat. When frying, oil in the pan can easily overheat and ignite. Heat oil slowly in an appropriately sized pot (covering the entire burner) to reduce the risk of boiling over and burning.

In the event of a range top grease fire, observe the following:

Switch OFF the range hood. Turn off the cook top then smother flames with a close fitting lid, cookie sheet or other metal tray. If the flames do not go out immediately.

EVACUATE AND CALL THE FIRE DEPARTMENT.

Never pick up a flaming pan – you may be burned. **DO NOT USE WATER** including wet dishcloths or towels, as a violent steam explosion may occur.

Functions

Island Range Hood –

Wireless Transmitter:

A: Light ON/OFF button

B: Blower Speed 1 (low) or OFF

C: Blower Speed 2 (medium)

D: Blower Speed 3 (high)

E: Blower Speed 4 (intensive)

F: 10 Minute Timer

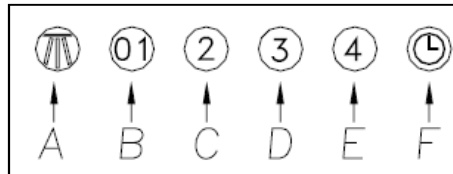

Filter requires washing indicator: after 30 hours of use, all the buttons will light up to remind you that the grease filter should be cleaned. Follow the instructions for cleaning filters in this booklet. Once the grease filters have been cleaned and replaced, reset by pressing the timer button (F). Do not rely solely on this indicator. Generally, the grease filter should be washed on a regular basis to avoid grease filter fires.

The blower should be turned on for approximately 5 minutes before cooking in order to establish air currents upward through the hood. Use the low speeds for normal use and the higher speeds for strong odors and fumes.

MAINTENANCE

The hood-fan should provide many years of trouble free service provided it is maintained properly.

Cleaning the Filter

Clean the grease filter either by carefully hand washing, (so as not to damage the filter design) or, preferably in a dishwasher. Depending on use, the filters should be cleaned at least every two weeks in a dishwasher.

If a carbon filter has been fitted this must be replaced at least every 6 months as a minimum. Depending on cooking style and nature of cooking (greasy foods, fry's, curries etc) would probably require more frequent replacement – if odors start to manifest themselves when cooking it is time to replace the carbon filter . We suggest you retain a spare set. These can be ordered from the supplier of your range hood.

Cleaning the Hood

Cleaning of the internal parts should be done with a clean damp (not excessively wet) cloth together with regular household detergent. The external stainless steel elements should be cleaned with a good quality foaming stainless steel cleaner. Read the manufacturers directions. Generally they recommend that the foam be sprayed onto a clean dry cloth and then applied to the stainless steel. Allow the foam to react on the surface for a few minutes and then wipe with a clean dry cloth.

On the surfaces that are exposed directly to heat from the cook-top, it is advisable to clean these on a regular basis to avoid the marks from becoming baked on.

Do not under any circumstances use an abrasive type cleaner as this will scratch and damage the stainless steel finish. Glass components should be cleaned with a product such as Windex.

Light Bulb Replacement

Turn blower and lights off. Make sure the lights are cool.

If new lights do not operate, check fuses and be sure globes and breakers are inserted correctly.

Do not remove the entire fixture (socket) as this is very difficult to reinstall. Gently pry the bulb from the fixture using a soft instrument such as a toothpick. Steel instruments will scratch the surface (refer to figure 2).

Replace the appropriate bulb. Check parts brochure or specification

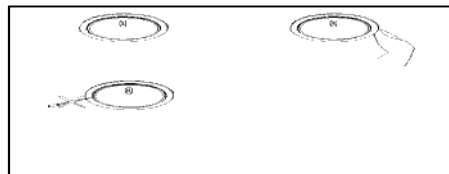

Figure 2

sheets on our website. Wipe both sides of the glass whilst it is out. Re-insert the glass-blocking ring and fasten it.

Three Year Limited Warranty

WARRANTY SERVICE

To qualify for warranty service, you must notify Sirius Range Hoods at the call toll free USA or Canada **1.877.275.9111** and provide the model number, description of the fault or defect and original date of purchase. Sirius reserves the right to request proof of original purchase. **Sirius will at its sole option and discretion replace products that arrive damaged through shipping, provided shipping damage is reported as stated above within 5 business days of receipt of the shipped product or products.**

ONE YEAR SERVICE REPAIR WARRANTY:

During the first year from date of original purchase, Sirius will, at its option, repair or replace, without charge, any product or part which is found to be defective under normal use and service.

THREE YEAR PARTS WARRANTY:

For three years from date of purchase, Sirius will provide free of charge, non-consumable replacement parts which are found to be defective under normal use and service.

WHO IS COVERED:

Sirius Range Hoods warrants to the original consumer purchaser of its products that such products will be free from defects in materials and workmanship for a period of three years from the original date of purchase. There are no other warranties, express or implied, including, but not limited to, implied warranties of merchantability or fitness for a particular purpose or application.

WHAT IS NOT COVERED:

This warranty does not extend to filters, lamps, batteries, ducts and ductwork components. This warranty does not cover normal maintenance and service or products or parts which have been subject to misuse, negligence, accident, improper maintenance or repair, faulty installation or installation contrary to recommended installation instructions. The warranty on glass screens is limited to manufacturing defects only and expressly excludes cracks and breakages as a result of faulty installation. *Labor and associated costs associated directly with removal and re-installation are expressly excluded.*

The duration of any implied warranty is limited to the three year period as specified for the express warranty. Some states and provinces do not allow limitation on how long an implied warranty lasts, so the above limitation may not apply to you.