



PV Series In-Line Centrifugal Duct Fans

For High Static Pressure Applications

Catalog PV01-Januray 2006



Power Vent
series

an *EefaCo.* Store
1-877-275-9111

Soler & Palau (S&P) USA and Canada are the most recent additions to, and are wholly owned subsidiaries of, Soler & Palau Group S.A. which was founded in 1951. S&P Group is the World's leading supplier of air movement products with an emphasis on developing and producing leading edge products to HVAC and other associated industries.

Over the past 50 years the company has expanded its product ranges and operations within Europe and beyond. Across the globe, S&P has established the most effective means through subsidiaries, distributors and partners for the distribution of our products. Today S&P has many companies, among these are: Australia, Belgium, China, England, France, Germany, Holland, Italy, Portugal, Mexico, the USA and Canada. Worldwide, S&P is represented by an established and renowned network of distributors and partner companies.

POWER VENT (PV) SERIES

The POWER VENT (PV) series of direct drive centrifugal in-line duct ventilation fans consists of six model sizes 4", 5", 6", 8" & 10" respectively. All models are designed for direct connection in-line with standard diameter round ducting. Airflow performance values range from 108 CFM (PV-100) up to 618 CFM (PV-250x).

All PV fan models incorporate a powerful external rotor motor that has been factory matched to a non-overloading backward curved centrifugal fan wheel.

This powerful combination enables the PV fans to deliver exceptional airflow performances against high static pressure typically found in ducted ventilation systems. All motors within PV fans are fully speed controllable using voltage or frequency control regulators.

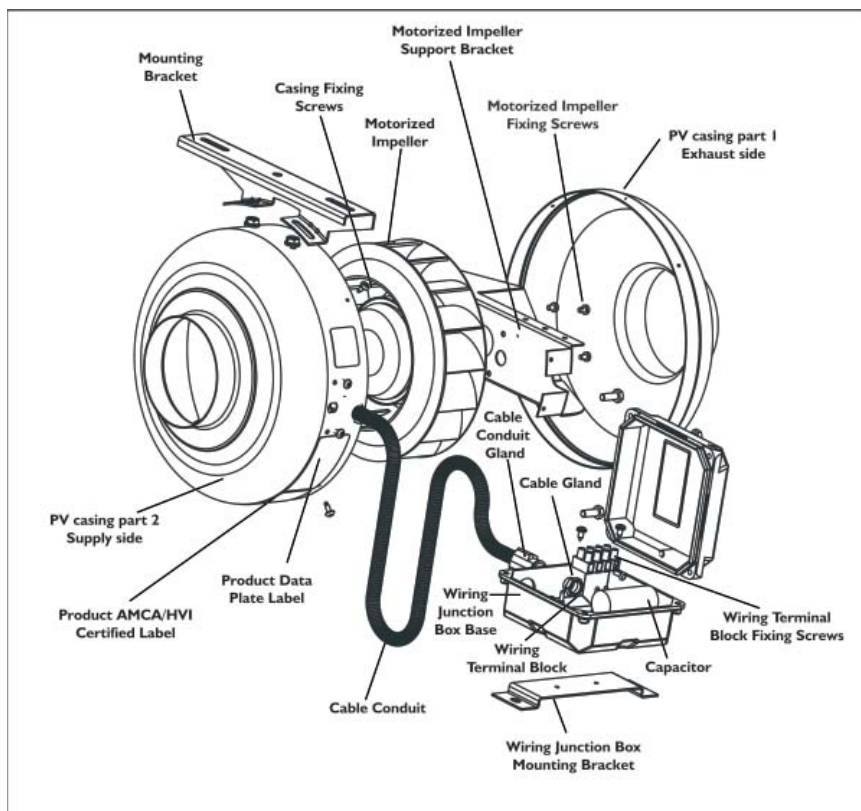

The PV series of duct exhaust or supply fans have been specifically designed for simple installation and many years of maintenance free operation. The PV fans can be mounted at any angle and at any point along the duct. The totally enclosed motor design allows the PV fans to operate in high moisture, lint and dust laden air. All models are manufactured with high quality materials and workmanship that is supported by a comprehensive **five (5) year warranty**.

All PV fans feature a corrosion resistant galvanized steel casing with a black baked enamel coating and are supplied with a strong mounting bracket and prewired remotely mounted wiring junction box. The fan is connected to the wiring junction box with a UL Listed flexible conduit that provides the installer with a completely flexible choice for positioning and installation.

an **SefaCo.** Store
1-877-275-9111

Applications

The PV fans are ideally suited for a wide range of residential, commercial and industrial exhaust and intake ventilation applications. Among typical applications would include the following:



Residential

- Kitchen Range Hoods
- Warm or Cool Air Transfer
- Bathrooms
- Utility Rooms
- Radon Mitigation



Commercial

- Conference Rooms
- Offices
- Bars & Restaurants
- Cafeterias
- Locker Rooms
- Make-Up Air Applications



Industrial

- Warehouses
- Welding Fume Extraction
- Spot Ventilation
- Equipment Cooling
- Workshops & Smoking Areas

Technical Specifications

All six PV model sizes (PV 100, 100x, 125x, 150x, 200x & 250x) include the following specifications:

Warranty

Five (5) year limited warranty.

Casing

- Manufactured from high grade pressed galvanized steel, with black baked enamel coating.
- Extra long inlet and discharge collars make installation quick and trouble free.
- Supplied with a strong galvanized steel mounting bracket.
- Supplied with a remote mounting, prewired wiring junction box.

Wheel / Impeller

- Backward curved centrifugal type.
- Factory matched to an external rotor motor and dynamically balanced to eliminate vibration.

Accessories

A wide range of accessories is available to complete the most demanding installation.

Motor

- Totally enclosed permanent split capacitor start and run external rotor motors.
- 115V 60Hz (single phase) electrical connection.
- Permanently sealed, self lubricating precision ball bearings.
- Safety Thermal Overload Protection Cut-Out (Automatic Reset Type).
- All Models are suitable for working airstreams up to 140° F

Code Approval

- All models have been independently safety tested by Underwriters Laboratories, Inc. and are UL and cUL Listed.
- Independently tested for Airflow Performance. The PV range is licensed to bear the AMCA seal for Air Performance.
- The PV product range is certified by the Home Ventilating Institute (HVI) for Air Performance.

an **EefaCo.** Store
1-877-275-9111



Power Vent series

Dimensions in inches/mm

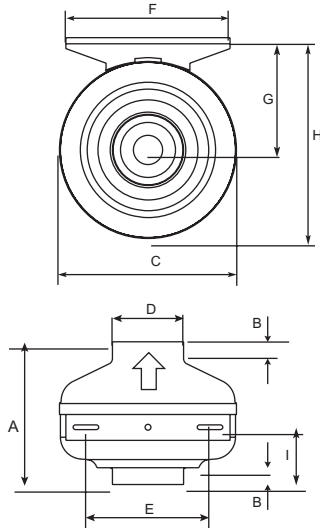

Model	A	B	C	D	E	F	G	H	I	Weight lbs(kgs)
PV-100	7 5/8 194	1 25	9 1/2 241	3 7/8 98	6 11/16 170	8 7/8 225	6 1/16 154	10 13/16 275	3 1/4 83	7 3.0
PV-100x	7 5/8 194	1 25	9 1/2 241	3 7/8 98	6 11/16 170	8 7/8 225	6 1/16 154	10 13/16 275	3 1/4 83	7 3.0
PV-125	7 5/8 194	1 25	9 1/2 241	4 7/8 124	6 11/16 170	8 7/8 225	6 1/16 154	10 13/16 275	3 7/16 87	7 3.0
PV-125x	7 5/8 194	1 25	9 1/2 241	4 7/8 124	6 11/16 170	8 7/8 225	6 1/16 154	10 13/16 275	3 7/16 87	7 3.0
PV-150	8 1/2 216	1 25	13 1/8 333	5 7/8 149	6 11/16 170	8 7/8 225	7 7/8 200	14 3/8 365	3 76	11 5.0
PV-150x	8 1/2 216	1 25	13 1/8 333	5 7/8 149	6 11/16 170	8 7/8 225	7 7/8 200	14 3/8 365	3 76	11 5.0
PV-200	8 1/2 216	1 25	13 1/8 333	7 7/8 200	6 11/16 170	8 7/8 225	7 7/8 200	14 3/8 365	3 11/16 94	11 5.0
PV-200x	8 1/2 216	1 25	13 1/8 333	7 7/8 200	6 11/16 170	8 7/8 225	7 7/8 200	14 3/8 365	3 11/16 94	11 5.0
PV-250	8 1/2 216	1 25	13 1/8 333	9 7/8 251	6 11/16 170	8 7/8 225	7 7/8 200	14 3/8 365	3 1/4 83	13 6.0
PV-250x	8 1/2 216	1 25	13 1/8 333	9 7/8 251	6 11/16 170	8 7/8 225	7 7/8 200	14 3/8 365	3 1/4 83	13 6.0
PV-315	9 1/16 230	1 25	15 5/16 401	12 5/16 312	6 11/16 170	8 7/8 225	9 3/16 234	17 1/8 435	3 1/2 89	21 10.0
PV-315x	9 1/16 230	1 25	15 5/16 401	12 5/16 312	6 11/16 170	8 7/8 225	9 3/16 234	17 1/8 435	3 1/2 89	21 10.0

Air Performance

Certified Ratings Program Trade Name	Model No.	Nom. RPM	Volts	Max. Watts	CFM v Static Pressure (SP) Ins. WG									Max. SP	Duct Dia. Ins.
					0"	0.125"	0.25"	0.375"	0.5"	0.75"	1.0"	1.25"	1.5"		
Power Vent-100	PV-100	1400	115	57	108	100	92	85	78	66	52	33	18	1.7	4"
Power Vent-100x	PV-100x	2880	115	84	153	142	130	120	111	96	80	63	34	1.85	4"
Power Vent-125	PV-125	2350	115	58	128	104	85	74	63	47	32	15	-	1.43	5"
Power Vent-125x	PV-125x	2745	115	85	206	190	170	153	135	110	88	62	33	1.77	5"
Power Vent-150	PV-150	2750	115	78	245	205	177	157	129	93	59	-	-	1.2	6"
Power Vent-150x	PV-150x	3075	115	149	438	420	395	368	335	285	240	203	161	2.29	6"
Power Vent-200	PV-200	3100	115	130	402	375	350	327	296	239	179	135	85	1.94	8"
Power Vent-200x	PV-200x	2930	115	180	544	515	485	446	415	360	312	273	230	2.64	8"
Power Vent-250	PV-250	3000	115	200	587	555	525	495	472	412	355	312	270	2.61	10"
Power Vent-250x	PV-250x	3045	115	214	618	595	570	540	510	450	390	340	297	2.8	10"
Power Vent-315	PV-315	2600	115	170	654	605	570	525	487	408	333	265	203	2.21	12.4"
Power Vent-315x	PV-315x	2650	115	370	942	905	859	811	762	622	508	440	390	3.9	12.4"

Performance certified is for installation type D-Ducted inlet, Ducted outlet. Performance ratings do not include the effects of appurtenances (accessories). Speed (RPM or RPS) shown is nominal. Performance is based on actual speed of test.

