

Fan Tech FKD Series Inline Centrifugal Fan Specifications

Dimensional Data

| Model | A | C | D | E | Weight |
|----------|----|--------|--------|-------|--------|
| FKD 8XL | 8 | 12 1/2 | 15 1/2 | 7 | 16 lbs |
| FKD 10 | 10 | 12 1/2 | 12 1/2 | 7 | 16 lbs |
| FKD 10XL | 10 | 14 | 15 | 8 | 22 lbs |
| FKD 12 | 12 | 14 | 12 1/2 | 8 | 21 lbs |
| FKD 14 | 14 | 17 7/8 | 17 1/4 | 1 | - |
| FKD 14XL | 14 | 19 3/4 | 20 1/4 | 1 1/2 | - |
| FKD 16 | 16 | 19 3/4 | 18 3/4 | 1 1/2 | - |
| FKD 16XL | 16 | 22 1/8 | 23 1/4 | 1 1/4 | - |
| FKD 18 | 18 | 22 1/8 | 21 3/4 | 1 1/4 | - |
| FKD 18XL | 18 | 22 1/4 | 29 1/4 | 2 | - |



Side View - FKD8XL

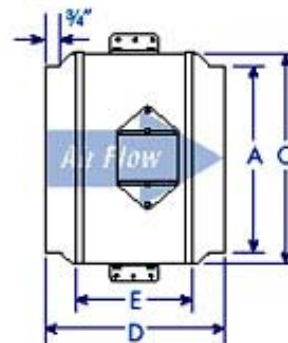

All dimensions in inches.

Dimensional Data

| Model | A | A1 | A2 | C | D | E | F |
|----------|----|----|----|--------|--------|-----|-------|
| FKD 12XL | 12 | 12 | 14 | 17 7/8 | 18 7/8 | 7/8 | 1 5/8 |

Side View - FKD12XL

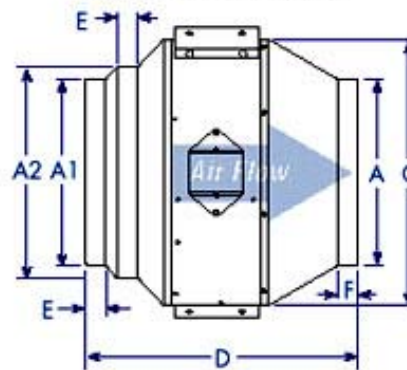

All dimensions in inches.

Performance Data

| Fan Model | RPM | Volts | Max. Watts | Max. Amps | 0" | .125" | .25" | .375" | .5" | .75" | 1.0" | 1.25" | 1.5" | 2.0" | Max. Ps | Duct Dia. | *Sones |
|-----------|------|-------|------------|-----------|------|-------|------|-------|------|------|------|-------|------|------|---------|-----------|--------|
| FKD 8XL | 2700 | 115 | 327 | 2.99 | 836 | 799 | 761 | 720 | 680 | 595 | 499 | 393 | 286 | - | 2.59" | 8" | 14.1 |
| FKD 10 | 2700 | 115 | 329 | 3.01 | 910 | 873 | 836 | 795 | 752 | 653 | 547 | 432 | 342 | - | 2.60" | 10" | 15.3 |
| FKD 10XL | 2850 | 115 | 529 | 4.84 | 1266 | 1226 | 1187 | 1147 | 1100 | 1006 | 911 | 810 | 696 | 460 | 3.08" | 10" | 21 |
| FKD 12 | 2900 | 115 | 531 | 4.86 | 1305 | 1266 | 1228 | 1189 | 1145 | 1054 | 948 | 833 | 712 | 479 | 3.08" | 12" | 23 |
| FKD 12XL | 1700 | 115 | 500 | 4.80 | 2016 | 1920 | 1832 | 1746 | 1649 | 1423 | 1066 | 606 | - | - | 1.52" | 12" | 18.7 |
| FKD 14 | 1700 | 115 | 495 | 4.76 | 2156 | 2061 | 1965 | 1868 | 1764 | 1520 | 1193 | 623 | - | - | 1.52" | 14" | 18.4 |
| FKD 14XL | 1550 | 115 | 738 | 7.12 | 2619 | 2517 | 2416 | 2303 | 2180 | 1936 | 1662 | 1294 | 843 | - | 1.94" | 14" | 19 |
| FKD 16 | 1600 | 115 | 742 | 6.39 | 2952 | 2831 | 2707 | 2580 | 2445 | 2144 | 1804 | 1306 | 774 | - | 1.90" | 16" | 18.5 |
| FKD 16XL | 1600 | 115 | 1421 | 12.40 | 4274 | 4144 | 4014 | 3880 | 3743 | 3452 | 3137 | 2794 | 2379 | 1242 | 2.42" | 16" | 25 |
| FKD 18 | 1600 | 115 | 1411 | 12.04 | 4448 | 4992 | 4130 | 3991 | 3871 | 3583 | 3239 | 2843 | 2380 | 1231 | 2.51" | 18" | 24 |
| FKD 18XL | 1700 | 460/3 | 2208 | 3.75 | 6236 | 6115 | 5995 | 5874 | 5754 | 5500 | 5199 | 4909 | 4602 | 3703 | 3.42" | 18" | 32 |

Performance shown is for installation type D - Ducted inlet, Ducted outlet. Speed (RPM) shown is nominal. Performance is based on actual speed of test. Performance ratings do not include the effects of appurtenances in the airstream.

* The sound ratings shown are loudness values in fan sones at 5ft. (1.5m) in hemispherical free field calculated per AMCA Standard 301. Values shown are for installation Type D: ducted inlet fan sone levels. Ratings do not include the effect of duct end correction. All sone values shown are calculated at 0.5" (static pressure in inches W.G.).