



# Fantech

Your Ventilation Solutions Company



## FEATURES

- Compact design
- Backward curved blade motors
- Electrostatic filters (washable)
- Aluminum heat recovery core
- External screw type dry contacts
- Airflow balancing using Fantech's "TRUE" motor adjustment feature
- Access doors on two sides of the cabinet for multiple installation arrangements and for better serviceability
- Improved core guide channels for easy removal of core

## OPTIONAL CONTROLS

- EDF 1 – On/Off, Low, High Speed Operation and 20 min. On/40 min. Off Cycle Timer
- RTS 3 – Intermittent Bathroom Timer with Settings for 20/40/60 Minutes of High Speed Boost
- EDF 5 – Digital multi-function wall control with recirculation
- EDF 2 – Digital multi-function wall control
- MDEH 2 – Mechanical low voltage dehumidistat with On/Off switch
- MDEH 1 – Mechanical low voltage dehumidistat
- RTS 2 – 15 Minute pushbutton timer
- AQS 1 – Air quality sensor

## WARRANTY

- 7 year on motors
- 5 year on parts
- Lifetime on core (limited)

Distributed by:

## Heat Recovery Ventilator Model SHR 3205RD

### SPECIFICATIONS

**CASE** 22 gauge galvanized steel. Powder coated finish, antique white. Insulated with 1" (25 mm) foil-face high density polystyrene foam to prevent condensation.

**MOTORS** Four (4) ebm™ direct drive external rotor motors with backward-curved blades. Motors come with permanently lubricated ball bearings for reliable operation.

**FILTERS** Four (4) Washable Electrostatic Panel Type Air Filters, 11.5" (292mm) x 11.4" (290mm) x 0.125" (3mm).

**CORE** Two (2) modular aluminum heat recovery cores configured for an efficient cross-flow ventilation. Each core is 12" x 12" (305 x 305 mm) with a 11.5" (292 mm) depth. Cores are manufactured to withstand extreme temperature variations.

**CONTROLS** External three (3) position (Low/Stand By/Medium) rocker switch that will offer continuous ventilation. Fantech offers a variety of external controls. (see optional controls)

**DEFROST** During the defrost sequence, a motorized damper temporarily blocks the incoming fresh air stream so that the warm air from the house can circulate through the HRV. The exhaust blower shuts down and the supply blower switches into high speed to maximize the effectiveness of the defrost strategy. During this cycle, household odors from the kitchen or bathroom are prevented from entering the home and the unit will not create negative pressure.

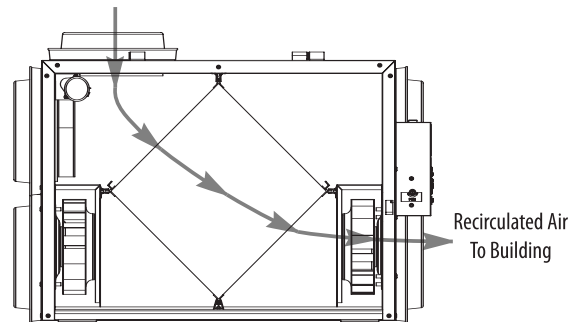

**INSTALLATION** Unit is typically hung by using installation kit supplied with unit. Mounting bolts provided on top four (4) corners of unit.

**SERVICEABILITY** Core, filters, motors and drain pan can be easily serviced through latched access doors located on front & back of the cabinet for multiple installation arrangements and for better serviceability. Core conveniently slides out with ease on an improved railing system. Electrical box, placed on the outside of the unit, can also be easily accessed.

## Dimensions & Airflow - All units feature three foot plug-in power cord with 3-prong plug.

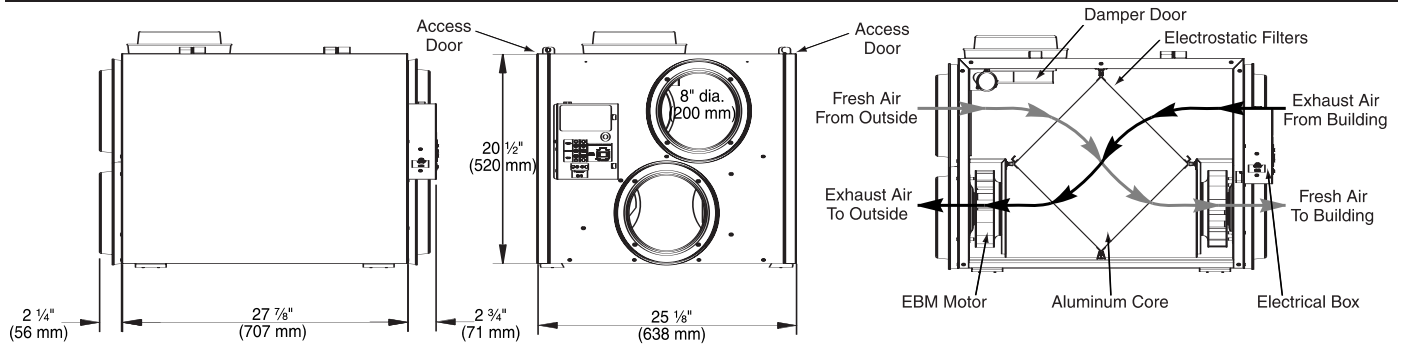

## Ventilation Performance

EXT. STATIC PRESSURE		NET SUPPLY AIR FLOW		GROSS AIR FLOW			
				SUPPLY		EXHAUST	
Pa	in wg	L/s	cfm	L/s	cfm	L/s	cfm
75	0.3	140	297	144	306	153	326
100	0.4	126	267	129	275	141	299
125	0.5	114	243	117	250	125	266
150	0.6	104	222	108	229	115	244
175	0.7	92	195	94	201	103	219
200	0.8	80	171	83	176	89	190
225	0.9	69	147	71	151	79	169
250	1.0	58	124	60	128	71	150
275	1.1	47	101	49	103	55	117
300	1.2	38	81	39	84	45	96
325	1.3	30	63	30	65	31	66
350	1.4	21	44	21	46	18	39

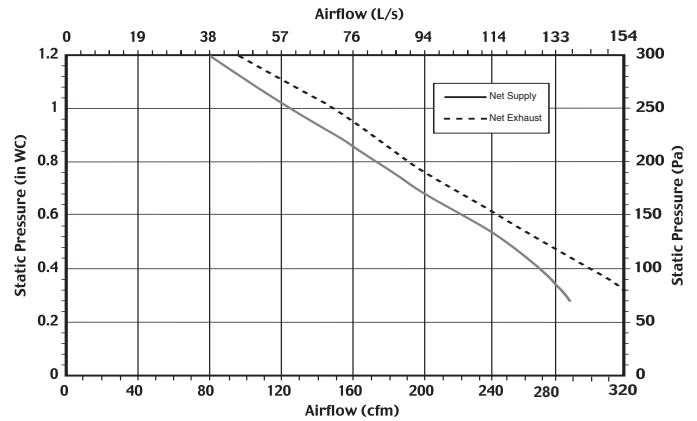

## Energy Performance

	SUPPLY TEMPERATURE		NET AIRFLOW		POWER CONSUMED WATTS	SENSIBLE RECOVERY EFFICIENCY	APPARENT SENSIBLE EFFECTIVENESS	LATENT RECOVERY/MOISTURE TRANSFER
	°C	°F	L/s	cfm				
Heating	0	32	56	118	136	66	77	0.02
	0	32	76	162	182	66	76	0.02
	0	32	116	248	272	64	74	0.03
	-25	-13	58	123	168	67	79	0.05

## Specifications and Ratings

- Model: SHR 3205RD
- Total assembled weight: 80 lbs (36.3 Kg)
- Cabinet: 22 ga. steel w/ powder coat finish
- Motors: ebm motor w/backward curved blades
- Filters: 4 washable electrostatic filters  
11.5" (292mm) x 11.4" (290mm) x 0.125" (3mm)

- Insulated with 1" (25 mm) foil-face high density polystyrene foam to prevent condensation and meet the requirements of the Underwriters Laboratories 94HF.
- Core: Aluminum  
12" (305mm) x 12" (305mm) x 11.5" (292 mm)

- Supply & exhaust ducts: 8" (200mm)
- Mounting: Suspended by chains & hooks
- Electrical requirements:  
Volts Frequency Amps Watts High Speed  
115V 60Hz 2.5A 300W  
3' plug-in power cord w/ 3-prong plug

