



Fantech

Your Ventilation Solutions Company



FEATURES

- Compact design
- Backward curved blade motors
- Electrostatic filters (washable)
- Aluminum heat recovery core
- External screw type dry contacts
- Airflow balancing using Fantech's "TRUE" motor adjustment feature
- Improved core guide channels for easy removal of core

OPTIONAL CONTROLS

- EDF 1 – On/Off, Low, High Speed Operation and 20 min. On/40 min. Off Cycle Timer
- RTS 3 – Intermittent Bathroom Timer with Settings for 20/40/60 Minutes of High Speed Boost
- EDF 5 – Digital multi-function wall control with recirculation
- EDF 2 – Digital multi-function wall control
- MDEH 2 – Mechanical low voltage dehumidistat with On/Off switch
- MDEH 1 – Mechanical low voltage dehumidistat
- RTS 2 – 15 Minute pushbutton timer
- AQS 1 – Air quality sensor

WARRANTY

- 7 year on motors
- 5 year on parts
- Lifetime on core (limited)

Distributed by:

an **SefaCo.** Store
1-800-667-8721

Heat Recovery Ventilator Model SHR 1505R

SPECIFICATIONS

CASE 24 gauge galvanized steel. Powder coated finish, antique white. Insulated with 1" (25 mm) foil-faced high density polystyrene foam to prevent condensation and meet the requirements of the Underwriters Laboratories 94HF.

MOTORS Two (2) German-engineered, factory-balanced ebm™ motors with backward curved blades. Motors come with permanently lubricated sealed bearings guarantee long life and maintenance-free operation. Seven (7) year warranty.

FILTERS Two (2) Washable Electrostatic Panel Type Air Filters, 8.5" (216mm) x 15" (380mm) x 0.125" (3mm).

CORE A aluminum heat recovery core configured for an efficient cross-flow ventilation. Core is 9" x 9" (229 x 229 mm) with a 15" (380 mm) depth. Cores are manufactured to withstand extreme temperature variations.

CONTROLS External three (3) position (Low/Stand By/Medium) rocker switch that will offer continuous ventilation. Fantech offers a variety of external controls. (see optional controls)

AIRFLOW BALANCING Screw type dial on electrical box allows supply airflow to be adjusted to match exhaust airflow.

DEFROST During the defrost sequence, a motorized damper temporarily blocks the incoming fresh air stream so that the warm air from the house can circulate through the HRV. The exhaust blower shuts down and the supply blower switches into high speed to maximize the effectiveness of the defrost strategy. During this cycle, household odors from the kitchen or bathroom are prevented from entering the home and the unit will not create negative pressure.

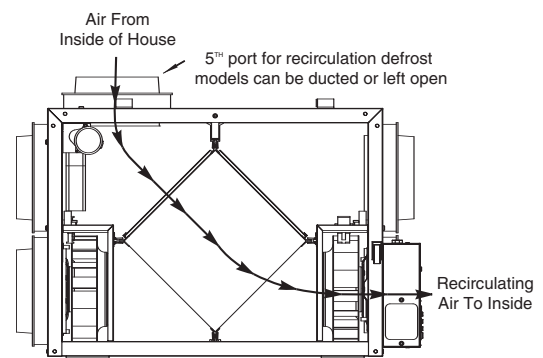

INSTALLATION Unit is typically hung by using installation kit supplied with unit. Mounting bolts provided on top four (4) corners of unit.

SERVICEABILITY Core, filters, motors and drain pan can be easily serviced through latched access door located on front of the cabinet. Core conveniently slides out with ease on an improved railing system. Electrical box, placed on the outside of the unit, can also be easily accessed.

Dimensions & Airflow - All units feature three foot plug-in power cord with 3-prong plug.

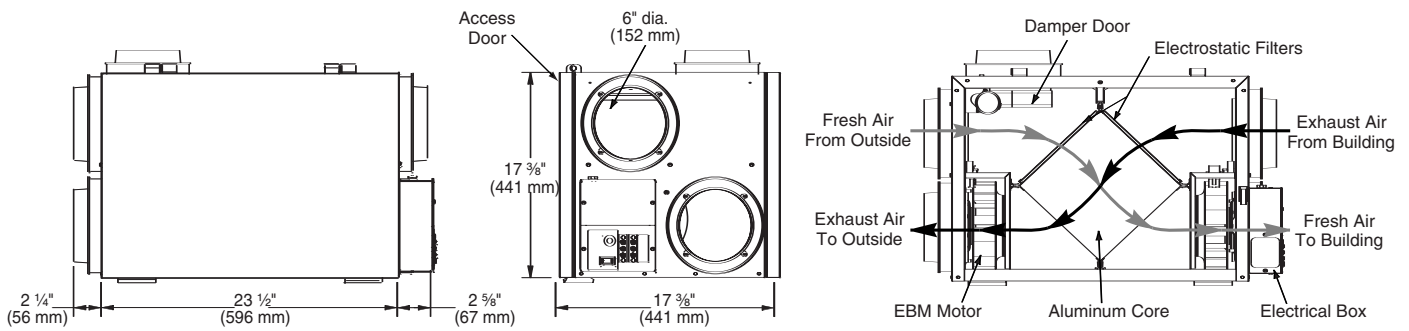

Ventilation Performance

EXT. STATIC PRESSURE		NET SUPPLY AIR FLOW		GROSS AIR FLOW SUPPLY EXHAUST			
Pa	in wg	L/s	cfm	L/s	cfm	L/s	cfm
25	0.1	78	167	80	169	86	182
50	0.2	74	158	75	160	79	168
75	0.3	71	150	72	152	75	160
100	0.4	67	142	68	144	68	145
125	0.5	65	137	66	140	63	135
150	0.6	58	124	59	126	58	123
175	0.7	52	110	53	112	52	110
200	0.8	47	100	48	101	46	98
225	0.9	42	89	43	91	40	84
250	1.0	36	76	36	77	34	71
275	1.1	28	60	28	60	27	58

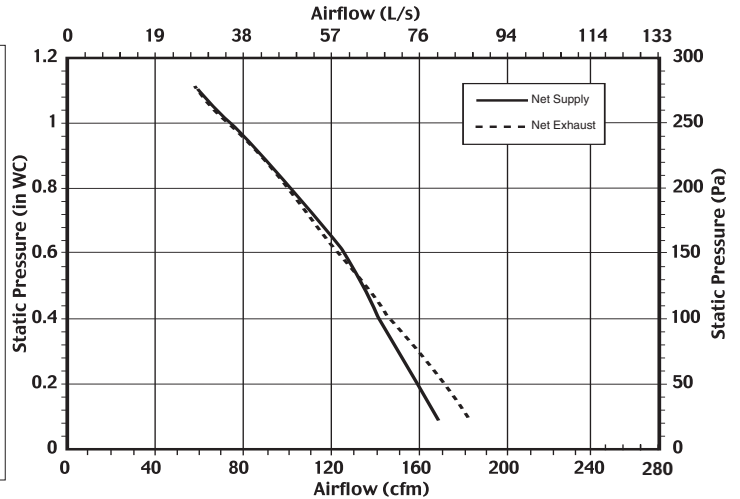

Energy Performance

	SUPPLY TEMPERATURE		NET AIRFLOW		POWER CONSUMED WATTS	SENSIBLE RECOVERY EFFICIENCY	APPARENT SENSIBLE EFFECTIVENESS	LATENT RECOVERY/MOISTURE TRANSFER
	°C	°F	L/s	cfm				
Heating	0	32	31	65	72	59	73	0.01
	0	32	49	104	102	61	70	0.00
	0	32	76	161	148	58	66	-0.01
	-25	-13	32	68	96	61	77	0.02

Specifications and Ratings

- Model: SHR 1505R
- Total assembled weight: 45 lbs
- Cabinet: 24 ga. steel w/ powder coat finish
- Motors: ebm motor w/backward curved blades
- Filters: 2 washable electrostatic filters
8.5" (216mm) x 15" (380mm) x 0.125" (3mm)
- Insulated with 1" (25 mm) foil-face high density polystyrene foam to prevent condensation and meet the requirements of the Underwriters Laboratories 94HF.
- Core: Aluminum
9" (229mm) x 9" (229 mm) x 15" (380 mm)
- Supply & exhaust ducts: 6" (152.4mm)
- Mounting: Suspended by chains & hooks
- Electrical requirements:
Volts Frequency Amps Watts
120V 60Hz 1.3A 150W ^{High Speed}
3' plug-in power cord w/ 3-prong plug



an *SefaCo.* Store
1-800-667-8721