



Fantech

Heat Recovery Ventilator

SH704

S = Side discharge

H = Heat recovery

704 = 70cfm, 4 port design



Compact HRV with easy-mount wall bracket. Brings a continuous supply of fresh air into a home while exhausting an equal amount of contaminated air. HRVs use what is called a "sensible" heat recovery core. This special core transfers heat from the exhaust air stream to the incoming air stream. Fresh incoming air is tempered by the heat that is transferred from the outgoing air to save on energy costs. The SH704 is equipped with automatic defrost mechanisms so even if you live in the coldest climates you can use your HRV all year long.

FEATURES

- Super Compact Size
- Includes Easy-Mount Wall Bracket
- Aluminum Heat Recovery Core
- 4" (100mm) Duct Connections
- No Balancing Required
- Easy Access Service Door
- 3' (914mm) Plug-in Power Cord
- Automatic Exhaust Defrost Allows Units to Always Stay in Ventilation Mode
- Only 25 lbs (11 kg)
- Electrostatic Filters (washable)
- Easy Core Guide Channels For Removing Core
- Single Speed Ventilation

ACCESSORIES

- FDT 7 – 7 Day Digital Programmable Timer
- COM 4P – 4" Weather Hoods (1 supply & 1 exhaust)
- FEL 4 – 4" 90° Elbow
- CG 4 – 4" Adjustable Grille

SPECIFICATIONS

CASE 24 gauge galvanized steel. Baked powder coated paint, antique white. Cabinet fully insulated with 1" (25 mm) aluminum foil-face high density polystyrene foam to prevent condensation and meet the requirements of the UL 94HF.

MOTORS Two (2) German-manufactured, factory-balanced ebm™ motors with backward curved blades. Motors come with permanently lubricated sealed ball bearings guarantee long life and maintenance-free operation. Seven (7) year warranty. Steep fan curves requires no balancing of airflows.

CORE Aluminum heat recovery core configured for efficient cross-flow ventilation. Core is 8.5" x 8.5" (216 x 216mm) with a 8" (203mm) depth. Cores are manufactured by Fantech to withstand extreme temperature variations.

FILTERS Two (2) Washable Electrostatic Panel Type Air Filters, 8.5" (216mm) x 8" (203mm) x 0.125" (3mm).

CONTROLS Unit is designed to operate continuously on a single speed. See FDT 7 under accessories or contact Tech Support for possible intermittent, line-voltage options.

DEFROST The automatic defrost cycle consists of a fan shutdown. When the supply air stream temperature goes below 23°F (-5°C), the supply motor shuts down while the exhaust motor continues to ventilate. Ambient air is passed through the unit for a period of 3 or 5 minutes. (see chart below) The supply motor will then re-start and run at the preset speed. This fan shutdown defrost cycle continues until the supply air stream rises above 23°F (-5°C).

Temperature range °F (°C)	Run/Defrost cycle (minutes)
23 (-5) to 14 (-10)	40 / 3
14 (-10) to 5 (-15)	30 / 5
5 (-15) & lower	20 / 5

SERVICEABILITY Core, filters, motors and drain pan can be easily accessed through latched door. Core conveniently slides out on our new easy glide core guides. 10" (250mm) of clearance is recommended for removal of core.

DUCT CONNECTION 4" (100mm) steel duct connections with rubber gasket for easy sealing.

DRAIN 1/2" (13mm) OD (outside diameter) drain spout (provided), and the entire bottom of unit covered by pan.

WARRANTY Limited lifetime on aluminum core, 7 years on motors, and 5 years on parts.

Dimensions & Airflow - All units feature three foot plug-in power cord with 3-prong plug.

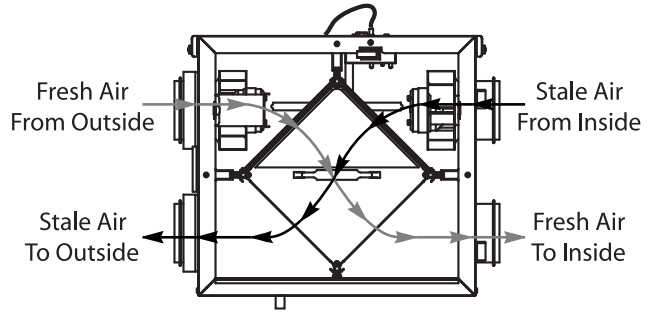
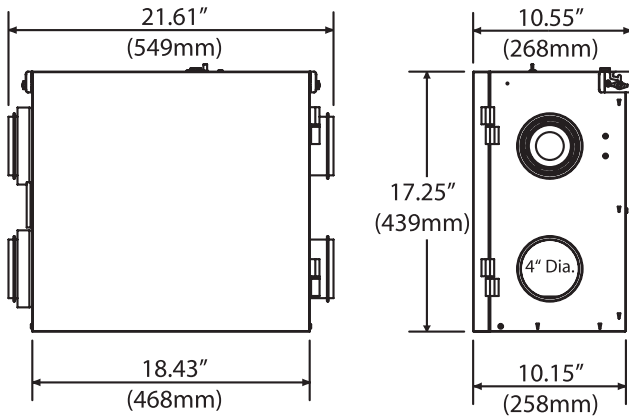

- Continuous ventilation mode of supply and exhaust airstreams
- 10" (254mm) of clearance is recommended for removal of core

Ventilation Performance

EXT. STATIC PRESSURE		NET SUPPLY AIR FLOW		GROSS AIR FLOW SUPPLY				EXHAUST	
Pa	in wg	L/s	cfm	L/s	cfm	L/s	cfm	L/s	cfm
25	0.1	45	96	47	99	49	104		
50	0.2	40	85	41	88	41	88		
75	0.3	32	67	33	69	34	72		
100	0.4	26	56	27	58	28	58		
125	0.5	20	42	20	43	20	43		

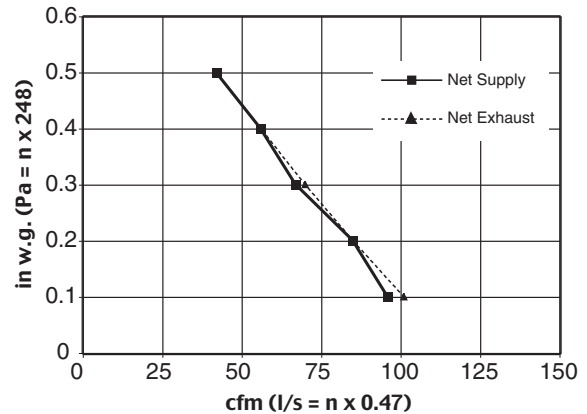

Energy Performance

	SUPPLY TEMPERATURE		NET AIRFLOW		POWER CONSUMED WATTS	SENSIBLE RECOVERY EFFICIENCY	APPARENT SENSIBLE EFFECTIVENESS	LATENT RECOVERY/MOISTURE TRANSFER
	°C	°F	L/s	cfm				
Heating	0	32	26	55	36	57	67	-
	0	32	32	68	40	55	63	-
	0	32	39	83	40	54	60	-
	-25	-13	34	72	35	53	66	-

Specifications and Ratings

- Model: SH704
- Total assembled weight: 25 lbs (11kg)
- Cabinet: 24 ga. steel w/powder coat finish
- Motors: ebm motors w/backward curved blades
- Filters: 2 washable electrostatic filters 8.5" (216mm) x 8" (205mm) x 0.125" (3mm)
- Insulated with 1" (25 mm) aluminum foil-face high density polystyrene foam to prevent condensation and meet the requirements of the UL 94HF.
- Core: Aluminum 8.5" (216mm) x 8.5" (216mm) x 8" (205mm)
- Supply & exhaust ducts: 4" (100mm)
- Mounting: Wall bracket included
- Electrical requirements:

Volts	Frequency	Amps	Watts
115V	60Hz	0.36A	40W

 3' plug-in power cord w/ 3-prong plug

Contacts

