

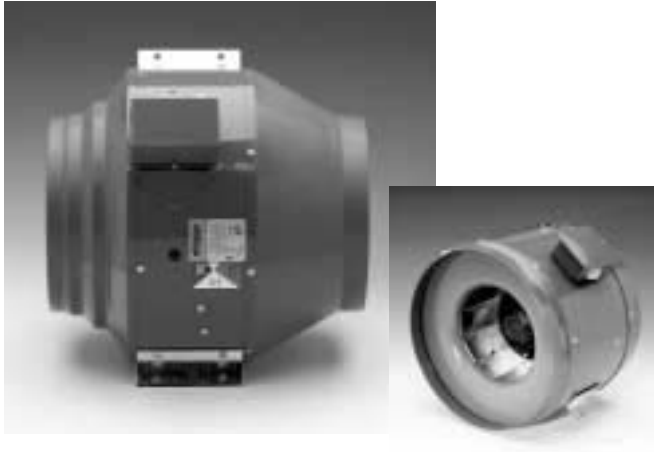

Fantech

INSTALLATION AND MAINTENANCE INSTRUCTIONS FOR MODEL FKD



1. The compactness and adaptability of the FKD Series fans permit easy installation. The fans are shipped fully assembled and can be mounted at any angle. For various mounting, see figures on the following page.
2. Because this unit has rotating parts, safety precautions should be exercised during all phases of installation, operation and maintenance.
3. **CAUTION:** "For General Ventilation Use Only. Do Not Use To Exhaust Hazardous Or Explosive Material and Vapors."
4. Remove unit from package and inspect within 15 days after receipt. If damaged, report damage to carrier. Do Not operate this unit with visible damage to the blower or impeller assembly.
5. **CAUTION:** "This unit has an unguarded impeller. Do not use in locations readily accessible to people or animals." **WEAR HAND PROTECTION AND STAY CLEAR OF SHARP EDGES!**
6. Screen guards must be installed within reach of personnel, within (7) feet of the working area, or when advisable for safety.
7. **PLEASE** read the entire manual before installing.

WARNING

Before installation, servicing or cleaning unit, switch power off at service panel and lock the service disconnecting means to prevent power from being switched on accidentally. When the service disconnecting means cannot be locked, securely fasten a prominent warning device, such as a tag, to the service panel.

Mounting Illustration 1

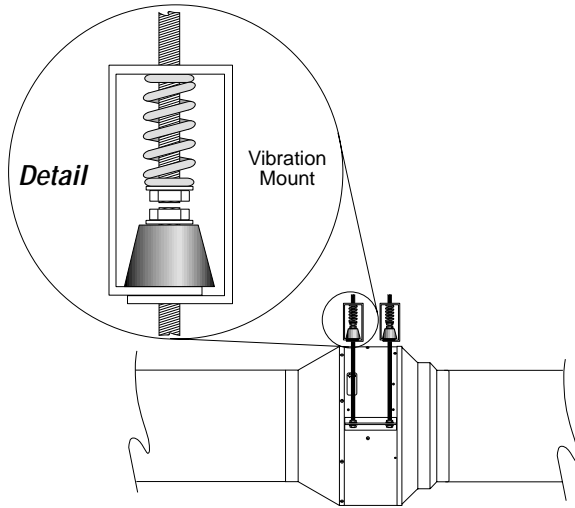

- Please follow all applicable codes when installing this unit
1. Equipment should be hung at its proper elevation by using temporary fixtures that can be removed after vibration hangers are installed.
 2. Hanger may be fastened directly to the structure or somewhere between suspended unit (be sure not to over tighten the neoprene element).
 3. Install hangers.
 4. Turn nuts on rod assembly clockwise one complete turn on each hanger. Repeat this procedure until temporary hanging fixtures are loose and load of piping or equipment is suspended completely on the vibration hangers.
 5. Remove temporary hanger fixtures and level piping or equipment by taking additional turns on the spring/top hanger rod nut – clockwise to raise, counterclockwise to lower as required.
 6. If equipping fan with isolators (FC Clamps), they should be attached at this time.
 7. See wiring section to complete installation.

Mounting Illustration 2

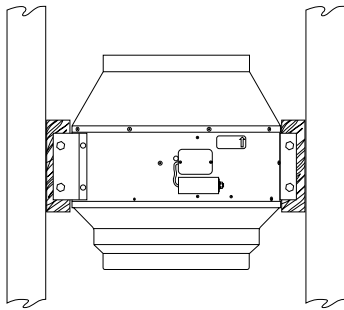

- Please follow all applicable codes when installing this unit
1. Install wood supports to structure for fan mounting.
 2. If equipping with vibration mounts, attach to supports.
 3. Attach fan to vibration mounts (be sure not to overtighten the neoprene element).
 4. If equipping fan with isolators (FC Clamps), they should be attached at this time.
 5. See wiring section to complete installation.

Mounting Illustration 3

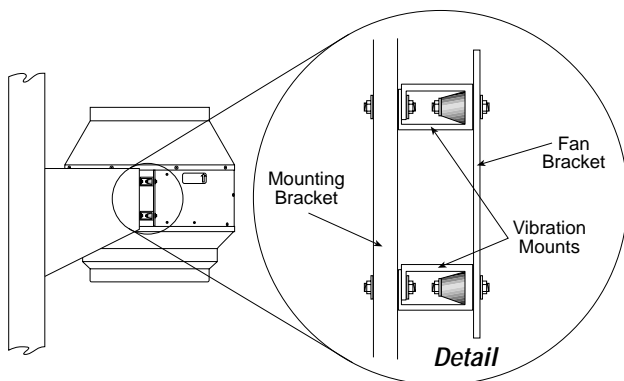

- Please follow all applicable codes when installing this unit
1. Create/Install angle wood supports to structure for fan mounting.
 2. If equipping with with vibration mounts, attach to supports.
 3. Attach fan to vibration mounts (be sure not to overtighten the neoprene element).
 4. If equipping fan with isolators (FC Clamps), they should be attached at this time.
 5. See wiring section to complete installation.

an **SefaCo.** Store
1-877-275-9111

Please Note: Vibration Mounts and Hardware are not supplied with fan. FC Clamps are sold separately.

Dimensions and Wiring (Models FKD 8XL, 10, 10XL, 12S, 12, 14S)

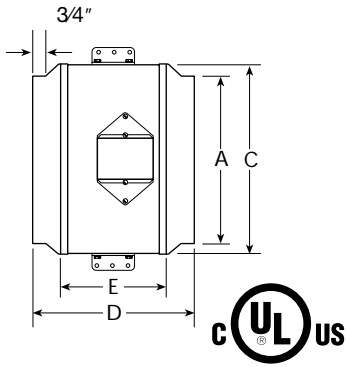

Dimensional Data

Model	A	C	D	E	Weight
FKD 8XL	8	12½	15½	7	19 lbs.
FKD 10	10	12½	12½	7	21 lbs.
FKD 10XL	10	14	15	8	15 lbs.
FKD 12S	12	12½	10	7	22 lbs.
FKD 12	12	14	12½	8	16 lbs.
FKD 14S	14	14	†	8	16 lbs.

All dimensions in inches. † FKD 14s overall length is 8"

115 Volt Single Phase Fans

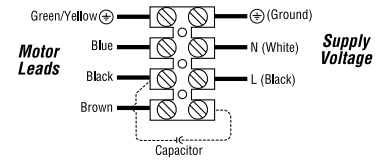

Dimensions and Wiring (Models FKD 12XL, 14, 14XL, 16, 16XL, 18, 18XL, 20)

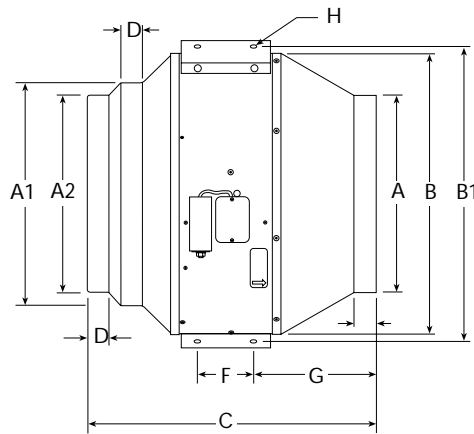

Dimensional Data

Model	A	A1	A2	B	B1	C	D	E	F	G	H	Weight
FKD12XL	12	-	12	17⅞	20¼	18⅞	7/8	15/8	4	7¾	3/8	45 lbs.
FKD14	14	-	14	19¾	22⅞	20¼	1½	15/8	4	11⅞	3/8	45 lbs.
FKD14XL	14	-	14	19¾	22⅞	20¼	1½	15/8	4	11⅞	3/8	55 lbs.
FKD16	16	16	-	19¾	22⅞	18¼	1½	15/8	4	9½	3/8	55 lbs.
FKD16XL	16	-	16	22⅞	24⅜	23¼	1¼	15/8	7/8	8½	1/2	85 lbs.
FKD18	18	18	-	22⅞	24⅜	21¾	1¼	15/8	7/8	7	1/2	85 lbs.
FKD18XL	18	-	18	28⅞	30⅜	30⅞	2	1¾	7/8	12½	1/2	95 lbs.
FKD20	20	20	-	28⅞	30⅜	30⅞	2	1¾	7/8	10½	1/2	95 lbs.

All dimensions in inches. † FKD 14s overall length is 8"

115/230 Volt Single Phase Fans

Wiring schematic for 4 lead motors, single phase

Notes:

- All leads are color coded as well as identified with an Alpha/Alpha or Alpha / Numeric code (i.e. TK or Z2). This code may be shown as a band on the wire or on a schematic on the motor hub. Colors should be verified against code band. If code band and color do not correspond to schematics above, wire according to the code on the band.
- Color of capacitor leads may be reversed. Fan operation will not be affected.

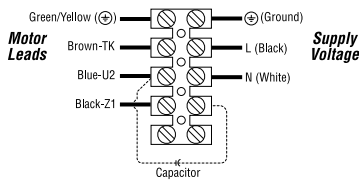

460 Volt Three Phase Fan

Notes:

- Contactor should be used. Control coil should be wired in series with motor thermal contacts (TK leads) as shown in diagram to provide thermal motor protection.
- All leads are color coded as well as identified with a band containing an Alpha/Alpha or Alpha/Numeric code (i.e. TK or Z2). Colors should be verified against code band. If code band and color do not correspond to schematics above, wire according to the code on the band.

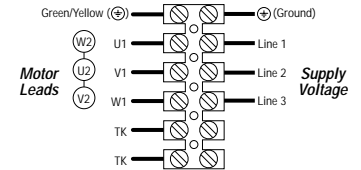

230 Volt Three Phase Fan

Notes:

- Contactor should be used. Control coil should be wired in series with motor thermal contacts (TK leads) as shown in diagram to provide thermal motor protection.
- All leads are color coded as well as identified with a band containing an Alpha/Alpha or Alpha/Numeric code (i.e. TK or Z2). Colors should be verified against code band. If code band and color do not correspond to schematics above, wire according to the code on the band.

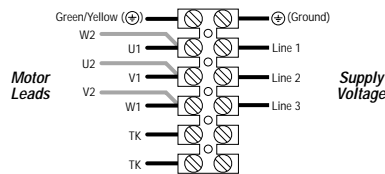

Contactor for 3-Phase Fans, 208-230/460V

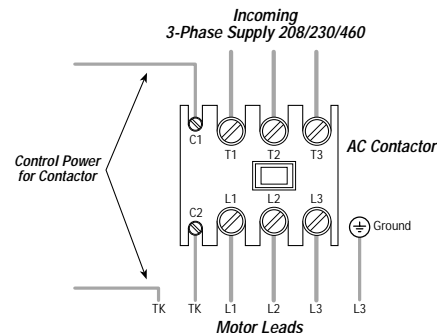

Three (3) Year Warranty

This warranty supersedes all prior warranties

FANTECH, INC. will repair or replace any part of your product that has a factory defect in workmanship or material. Product must be returned to point of purchase, with Bill of Sale, within three (3) years of purchase. If factory return is required, as determined by rep/distributor, the warrantee assumes all cost to and from the factory.

THE FOLLOWING WARRANTIES DO NOT APPLY:

- a) To damages from shipping, either concealed or visible;
- b) To damages resulting from improper wiring or installation;
- c) To damages or failure caused by Acts of God, or resulting from improper consumer procedures such as
 - 1) improper maintenance,
 - 2) misuse, abuse, abnormal use, or accident and
 - 3) incorrect electrical voltage or current;
- d) To removal of or any alteration to the Fantech label, control number or date of manufacture;
- e) To any other warranty, expressed, implied or written, and to any consequential or incidental damages, loss of property, revenues, or profit or costs of removal, or reinstallation, for any breach of warranty.

WARRANTY VALIDATION

The end user must keep a copy of the Bill of Sale to verify purchase date. Valid proof of the date of installation may also serve as a verification of commencement of warranty period.

FANTECH RETURN POLICY

Claims for damages or shortages must be reported within ten (10) days of receipt of product(s). For any product(s)

received damaged by the forwarding agent, THE FOLLOWING INSTRUCTIONS MUST BE FOLLOWED:

- 1) For product delivered by UPS:
 - a) Concealed Damages: Keep all cartons. Call UPS for an inspection and notify Fantech immediately.
 - b) Visible Damages: Save all cartons and file complaint directly with UPS.
- 2) For product delivered via a common carrier: File damaged goods claim directly with the freight company.
- 3) Shortages: Sign only for the total number of pieces received and call Fantech immediately.

FOR FACTORY RETURN

Product(s) returned without authorization will not be accepted. Fantech will not accept the return of any special, non-stock, obsolete or unsalable product(s). Fantech may, at its option, accept return of salable product(s) subject to a 25% restocking charge.

- 1) No product(s) will be accepted without a Return Materials Authorization (RMA) number. This number can be obtained by calling Fantech, Inc. at 800-747-1762. Please have Bill of Sale or proof of date of installation available.
- 2) RMA must be clearly marked on outside of carton or delivery will be refused. All product(s) must be returned freight prepaid.
- 3) Product(s) will be repaired/replaced and shipped back to buyer; no credit will be issued.
- 4) Any out of warranty product will be evaluated and buyer will be notified of cost; repair cost will be charged to customer; buyer will be responsible for return freight or product may be returned without action, to the buyer, freight collect. No credit will be issued.

Limitation of Warranty and Liability

This warranty does not apply to any FANTECH product or part which has failed as a result of faulty installation or abuse, incorrect electrical connections or alterations made by others, or use under abnormal operating conditions or misapplication of the product or parts. We will not approve for payment any repair not made by us or our authorized agent without prior written consent. The foregoing shall constitute our sole and exclusive warranty and our sole exclusive liability, and is in lieu of any other warranties, whether written, oral implied or statutory. There are no warranties which extend beyond the description on the page hereof. In no event, whether as a result of breach of contract, or warranty or alleged negligence, defect incorrect advice or other causes, shall FANTECH be liable for special or consequential damages, including, but not limited to, loss of profits or revenue, loss of use of equipment or any other associated equipment, cost of capital, cost of substitute equipment, facilities or services, downtime costs, or claims of customers of purchase for such damages. FANTECH neither assumes or authorizes any person to assume for it any other liability in connection with the sale of product(s) or part(s). Some jurisdictions do not allow the exclusion or limitation of incidental or consequential damages so the above limitations and exclusions may not apply to you.

Warning

FANTECH, INC. products are designed and manufactured to provide reliable performance, but they are not guaranteed to be 100% free from defects. Even reliable products will experience occasional failures and this possibility should be recognized by the user. If these products are used in a life support ventilation system where failure could result in loss or injury, the user should provide adequate backup ventilation, supplementary natural ventilation, failure alarm system, or acknowledge willingness to accept the risk of such loss or injury.

an *Sefa* Co. Store
1-877-275-9111