



# Fantech

## Whole House HEPA Filtration System



### True HEPA Filtration for Your Entire Home!

- Collects 99.97% of airborne particles and allergens down to 0.3 microns including smoke and dust particles, animal dander, dust mites, bacteria and attached viruses
- Cleans the air in an average house once each hour
- Easily connects to existing ductwork of forced air furnace or air handler



#### Choose From Three Different Models:

**Model DM 3000** – Duct Mount unit features backplate which allows direct connection of unit to air handler or furnace.

**Model CM 3000** – Compact, easy to install Collar Mount unit comes with four collars, two pieces of UL Listed 8" flex duct and hanging chains.

**Model CM3000 I** – Insulated version of the CM3000 for use in unconditioned spaces such as attics and garages. Insulated outer shell prevents condensation problems. Includes hanging chains.



Uniquely designed with three filters positioned parallel to the airstream. Powerful, German engineered 240 CFM motor provides long life and dependable operation.

an **SefaCo.** Store  
1-800-667-8721

# Fantech's Whole House HEPA Filtration Unit is Easy to Install

- Can be installed in your basement, heated crawl space, or even your closet
- Can be installed independently, on your furnace, forced air handler or combined with your ventilation system

Model	Volts	Amp Rating	CFM	5' Cord w/ 3-Prong Plug
DM 3000	115V	1.0A	240	Yes
CM 3000	115V	1.0A	240	Yes
CM 3000I	115V	1.0A	240	Yes



Fantech's Whole House Hepa Filtration Units carry a 7 year (limited) warranty on the motor and a 5 year (limited) warranty on parts. \*

\*Filters not included in warranty

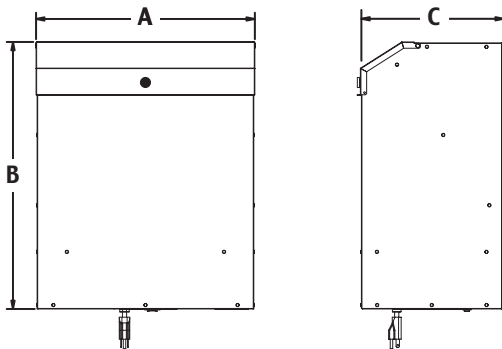

Model	DM 3000	CM3000	CM3000 I
Height (B)	20"	20"	20 3/8"
Width (A)	16"	16"	16 3/8"
Depth (C)	10 1/2"	10 1/2"	10 7/8"
Port	(2) 5" x 10"	(2) 8" Dia.	(2) 8" Dia.

## Installation examples:

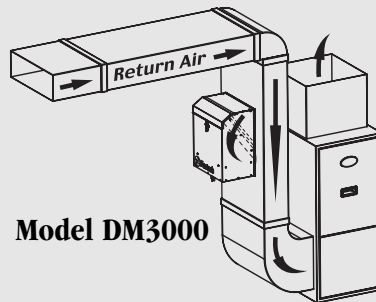

**Model DM3000**

Unit installs on the return air side duct. Air is directed through the by-pass HEPA unit allowing the heating/cooling system to easily deliver clean, fresh healthy air throughout the entire home.

Use Model CM3000 I for installation in unconditioned spaces such as an attic or garage. Mounts horizontally or vertically. Use independently or on an existing forced air furnace or air handler.

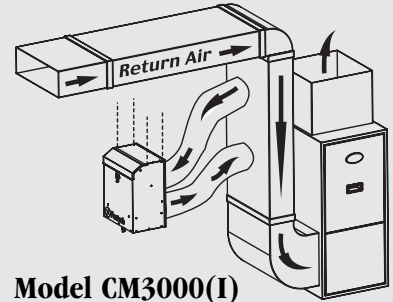

**Model CM3000(I)**



# Fantech