



Fantech

Installation Instructions for Model CVS

READ & SAVE THESE INSTRUCTIONS!

an **SefaCo.** Store
1-800-667-8721

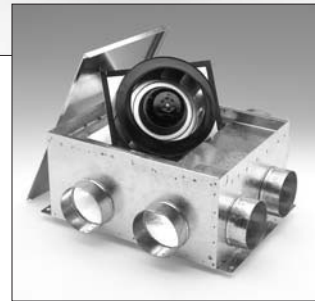

Top: 2-port model
CVS275A

Left: 4-port models
CVS300A &
CVS400A

IMPORTANT:
READ THESE INSTRUCTIONS COMPLETELY BEFORE INSTALLING FAN
AND SAVE THESE INSTRUCTIONS FOR FUTURE REFERENCE.

Items included: One (1) ducted exhaust fan
One (1) installation sheet

WARNING - TO REDUCE THE RISK OF FIRE, ELECTRIC SHOCK, OR INJURY TO PERSONS, OBSERVE THE FOLLOWING:

- Use this unit only in the manner intended by the manufacturer. If you have questions, contact the manufacturer.
- Before Servicing or Cleaning Unit, Switch Power Off At Service Panel and Lock Service Panel To Prevent Power From Being Switched On Accidentally.
- Installation Work And Electrical Wiring Must Be Done By Qualified Person(s) In Accordance With All Applicable Codes And Standards, Including Fire-Rated Construction.
- The combustion airflow needed for safe operation of fuel-burning equipment may be affected by this unit's operation. Follow the heating equipment manufacturer's guideline and safety standards such as those published by the National Fire Protection Association (NFPA), and the American Society for Heating, Refrigeration and Air Conditioning Engineers (ASHRAE), and the local code authorities.
- When cutting or drilling into walls or ceilings, do not damage electrical wiring and other hidden utilities.
- Ducted fans must always be vented to the outdoors.
- If this unit is to be installed over a tub or shower, it must be marked as appropriate for the application.
- NEVER place a switch where it can be reached from a tub or shower.
- FOR INTERIOR USE ONLY
- DO NOT USE WITH HEATED AIR IN EXCESS OF 60°C (140°F).
- CAUTION: For General Ventilation Use Only. Do Not Use To Exhaust Hazardous Or Explosive Materials And Vapors.

WARNING

FANTECH products are designed and manufactured to provide reliable performance, but they are not guaranteed to be 100% free from defects. Even reliable products will experience occasional failures and this possibility should be recognized by the user. If these products are used in a life support ventilation system where failure could result in loss or injury, the user should provide adequate backup ventilation, supplementary natural ventilation, failure alarm system, or acknowledge willingness to accept the risk of such loss or injury.

INSTALLING THE MOUNTING CASING AND FAN

STEP 1.

When selecting a fan mounting location, the following criteria should be considered: a) type of application; b) service accessibility; and c) mounting to minimize noise generated by fan operation.

- a) Intermittent ventilation - i.e. bathroom exhaust, kitchen area exhaust; continuous ventilation for indoor air quality. Important Notice: When using the fan in a continuous system, adequate makeup air should be provided in order to prevent backdrafting of combustion appliances.
- b) Fan location should allow sufficient access for service.
- c) Mounting the fan as far as possible from the exhaust point will minimize fan operating noise from being transmitted back through the duct work. If the fan is to be used as a booster for moving the air between two rooms, a central point along the duct may be optimal. Insulated type duct work (recommended for all bathroom exhaust applications) will also result in quieter operation.

STEP 2.

To fasten the mounting casing to the ceiling, use either threaded rod or wires to suspend the unit from the ceiling. You may also install the unit by fastening it to a frame using either wood or sheet-metal screws depending on the surface to which you chose to attach the unit. The frame should be designed to eliminate vibration.

STEP 3.

Connect duct work to inlet and outlet of fan using FC clamps or duct tape. When using insulated duct, it is recommended that the inner vinyl core be clamped or taped to the inlet and outlet collar and that the vapor barrier surrounding the insulation be duct taped to the side of the unit.

INSTALLING THE SUPPLY/EXHAUST GRILL

STEP 1.

Select the grill mounting point within the area to be ventilated. To ease installation, locations of framing beams within the walls or joists supporting the ceiling should be considered.

STEP 2.

Place the mounting collar in the selected location and trace a circle onto the surface. From the interior side of the room, cut through the surface. Please note: in order to assure a smoother finish when mounting through a sheetrock or tile type ceiling, it is recommended that a razor knife be used to make the cut.

STEP 3.

From within the attic or crawl space, place the ducting into the hole until the edge of the duct is flush with the interior wall or ceiling surface. Attach collar to the the duct work and clamp or tape into place, if necessary. If grills are equipped with mounting screws, install them before installing the duct work.

STEP 4.

Insert grill.

an **SefaCo.** Store
1-800-667-8721

ELECTRICAL CONNECTIONS

DO NOT CONNECT POWER SUPPLY UNTIL FAN IS COMPLETELY INSTALLED.
MAKE SURE ELECTRICAL SERVICE TO THE FAN IS LOCKED IN "OFF" POSITION.

STEP 1.

Punch out the knockout on the same side as where the female plug-in cover is located. Note that it is possible to place the plug-in on the other side of the unit by simply removing the screw securing the cover and installing it on the other side where a pre-drilled hole is provided. Remember to also move the grounding screw to the same side as the female plug.

STEP 2.

Run the two lead wires through the knockout. Connect the electrical power source (see wiring diagram). Use wire connectors-insulators to join each lead wire to the power source. Fasten the ground wire from the electrical source to the screw provided (indicated by the ground symbol \perp).

If the motor assembly is already installed and plugged into the female plug-in, skip step 3 and 4.

STEP 3.

Insert the motor assembly into the square hole so that the mounting holes align. Hint: Insert one side of the motor assembly and slide it so that the fan is partially under the motorplate, then insert the other side. Fasten with four (4) sheet metal screws, included.

STEP 4.

Before starting the unit, turn the fan by hand to assure a free rotation. If it hits the orifice, check the screws holding the motor bracket. Adjustments can be made by loosening the motor bracket screws.

STEP 5.

Plug in the motor assembly to the female plug-in.

STEP 6.

Place the cover on top of the unit and fasten with the two (2) sheet metal screws provided.

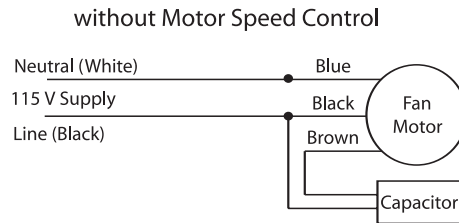
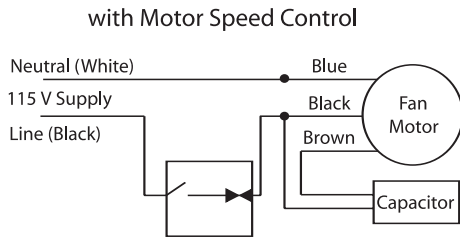

Multiple Location Switching Wiring Diagram

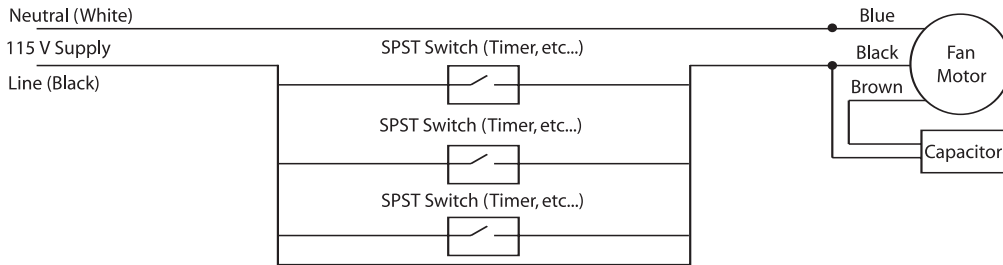

DIMENSIONS

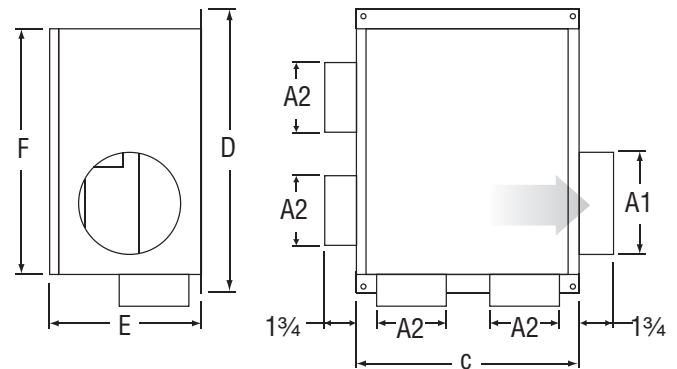
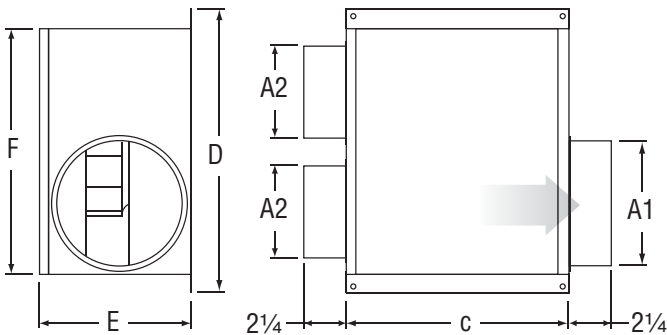

Model	A1	A2	C	D	E	F
CVS275A	6	5	11	15	7 ³ / ₄	12

Model	A1	A2	C	D	E	F
CVS300A	6	4	13	18 ³ / ₄	8 ¹ / ₄	16
CVS400A	6	4	13	18 ³ / ₄	8 ¹ / ₄	16

Five (5) Year Warranty

DURING ENTIRE WARRANTY PERIOD:

FANTECH will repair or replace any part which has a factory defect in workmanship or material. Product may need to be returned to the Fantech factory, together with a copy of the bill of sale and identified with RMA number.

FOR FACTORY RETURN YOU MUST:

The Distributor may place an order for the warranty part and/or product and is invoiced. The Distributor will receive a credit equal to the invoice only after product is returned prepaid and verified to be defective.

FANTECH WARRANTY TERMS DO NOT PROVIDE FOR REPLACEMENT WITHOUT CHARGE PRIOR TO INSPECTION FOR A DEFECT. REPLACEMENTS ISSUED IN ADVANCE OF DEFECT INSPECTION ARE INVOICED, AND CREDIT IS PENDING INSPECTION OF RETURNED MATERIAL. DEFECTIVE MATERIAL RETURNED BY END USERS SHOULD NOT BE REPLACED BY THE DISTRIBUTOR WITHOUT CHARGE TO THE END USER, AS CREDIT TO DISTRIBUTOR'S ACCOUNT WILL BE PENDING INSPECTION AND VERIFICATION OF ACTUAL DEFECT BY FANTECH.

THE FOLLOWING WARRANTIES DO NOT APPLY:

- Damages from shipping, either concealed or visible. Claim must be filed with freight company.
- Damages resulting from improper wiring or installation.
- Damages or failure caused by acts of God, or resulting from improper consumer procedures, such as:
 1. Improper maintenance
 2. Misuse, abuse, abnormal use, or accident, and
 3. Incorrect electrical voltage or current.
- Removal or any alteration made on the FANTECH label control number or date of manufacture.
- Any other warranty, expressed, implied or written, and to any consequential or incidental damages, loss or property, revenues, or profit, or costs of removal, installation or reinstallation, for any breach of warranty.

WARRANTY VALIDATION

- The user must keep a copy of the bill of sale to verify purchase date.
- These warranties give you specific legal rights, and are subject to an applicable consumer protection legislation. You may have additional rights which vary from state to state.

an **SefaCo.** Store
1-800-667-8721

Limitation of Warranty and Liability

This warranty does not apply to any FANTECH INC. product or part which has failed as a result of faulty installation or abuse, incorrect electrical connections or alterations made by others, or use under abnormal operating conditions or misapplication of the product or parts. We will not approve for payment any repair not made by us or our authorized agent without prior written consent. The foregoing shall constitute our sole and exclusive warranty and our sole exclusive liability, and is in lieu of any other warranties, whether written, oral, implied or statutory. There are no warranties which extend beyond the description on the page hereof. In no event, whether as a result of breach of contract, or warranty or alleged negligence, defect incorrect advice or other causes, shall FANTECH be liable for special or consequential damages, including, but not limited to, loss of profits or revenue, loss of use of equipment or any other associated equipment, cost of capital, cost of substitute equipment, facilities or services, downtime costs, or claims of customers of purchase for such damages. FANTECH neither assumes or authorizes any person to assume for it any other liability in connection with the sale of product(s) or part(s). Some jurisdictions do not allow the exclusion or limitation of incidental or consequential damages so the above limitations and exclusions may not apply to you.

Warning

FANTECH, INC. products are designed and manufactured to provide reliable performance, but they are not guaranteed to be 100% free from defects. Even reliable products will experience occasional failures and this possibility should be recognized by the user. If these products are used in a life support ventilation system where failure could result in loss or injury, the user should provide adequate backup ventilation, supplementary natural ventilation, failure alarm system, or acknowledge willingness to accept the risk of such loss or injury.