

The Fitzgerald®

OF6320 Series

an *SefaCo.* Store
1-800-667-8721



SPECIFICATION SHEET



Product Specifications subject to change

The Fitzgerald® Fan Assembly – OF6320**

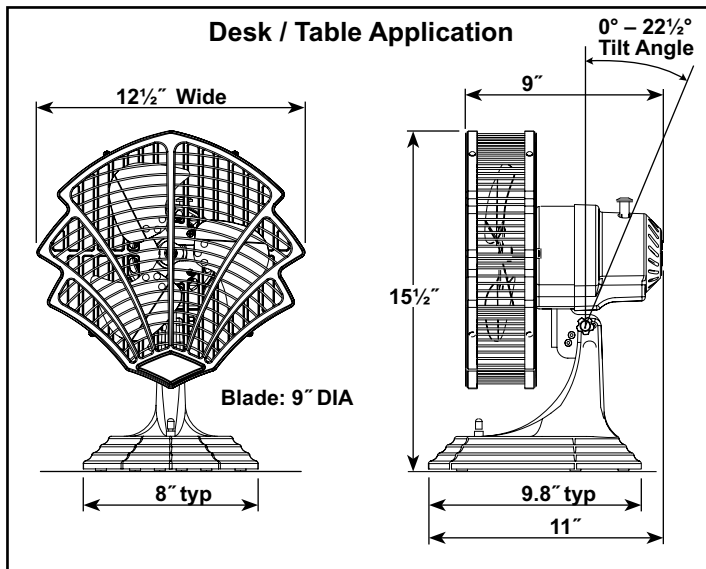
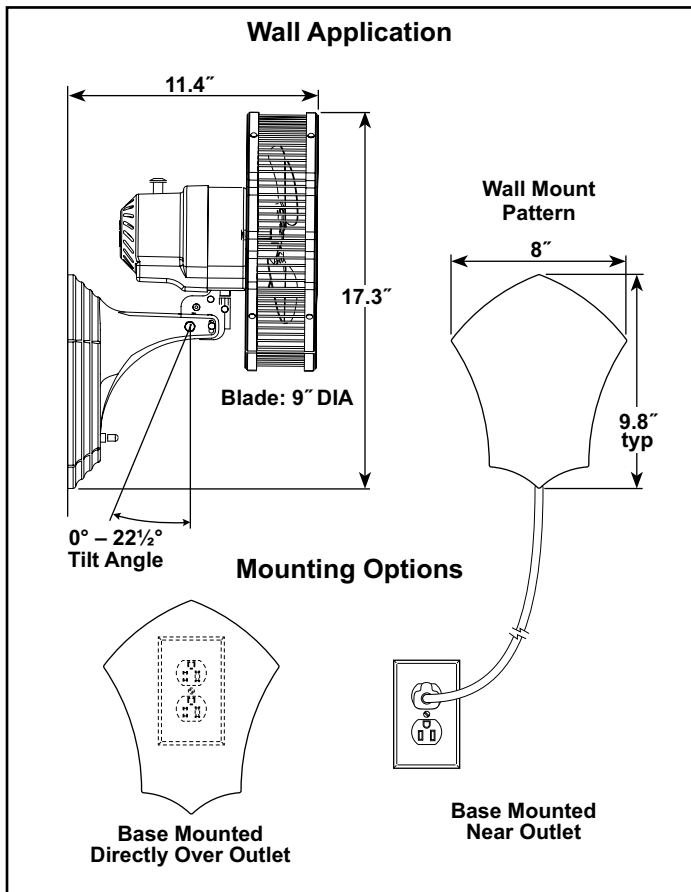

Available Finishes	
OB	Oil-Rubbed Bronze
SN	Satin Nickel

All Dimensions Shown In Inches

ELECTRICAL REQUIREMENTS:

Table / Wall fan requires a grounded electrical supply line of 120 volts AC, 60 Hz, 15 amp circuit.
8 ft power cord included.

CONTROL / SPEED:

The 4-position rotary switch control is included. Each switch setting consist of 3 separate, non-reversing fan speed and off. Not applicable for ceiling fan wall controls.
High – 1700 rpm; Med – 1450 rpm; Low – 1300 rpm

FEATURES:

- Includes 8 ft power cord
- Oscillates 82°
- Can be mounted on wall, near or directly over outlet (mounting bracket included)
- Includes protective rubber feet
- Weighs 10 lbs
- Ships fully assembled

DAMP LOCATION:

Fan not rated for Damp Location usage.



an *SefaCo.* Store
1-800-667-8721

