

## MODEL RP1 SERIES PRO-STYLE RANGE HOOD

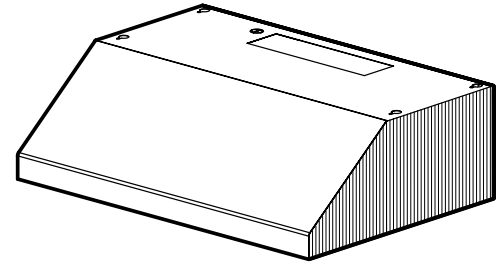

Designed to meet the performance needs of today's conventional cooking appliances.

### FEATURES

- Two-speed rocker control with solid state blower memory
- Two-position light switch for "bright" or "night-light" illumination
- Dual halogen lamps with stainless steel trim rings (50W GU10 - MR16 lamps, purchase separately)
- High efficiency dual centrifugal blower with resilient anti-vibration motor mounts
- Broan Heat Sentry™ - automatically turns blower to high speed when excess cooking heat is detected
- Two washable, micromesh aluminum grease filters
- Hemmed bottom for safety and good looks
- Damper/duct connector included
- Professional styling in Stainless Steel, Black and White
- Available in 30" and 36" widths
- Replacement filters (package of 2):  
- Grease - 97017455 (BPRPFA)

### SPECIFICATIONS

VOLTS	AMPS	RPM	SONES		CFM		DUCT
			VER.	HOR.	VER.	HOR.	
120	7.0	1625	7.0	7.0	440	440	3 1/4" x 10"



HVI-2100 CERTIFIED RATINGS comply with new testing technologies and procedures prescribed by the Home Ventilating Institute, for off-the-shelf products, as they are available to consumers. Product performance is rated at 0.1 in. static pressure, based on tests conducted in AMCA's state-of-the-art test laboratory. Sones are a measure of humanly-perceived loudness, based on laboratory measurements.

### TYPICAL SPECIFICATION

Range hood shall be Broan RP1 Series.

Unit shall have a backdraft damper and be ducted vertically (horizontally) to the outside.

Unit shall have washable micromesh aluminum filters.

Unit shall have a permanently lubricated, dual centrifugal blower resiliently mounted and controlled with an infinite speed, solid state control. RPM not to exceed 1625.

Hood shall have a two-speed rocker control and a separate, two-position light switch. Sides shall be straight and bottom hemmed - with no sharp edges. Stainless steel shall be 24-gauge, 430 series.

Air delivery shall be no less than 440 cfm and sound levels no greater than 7.0 Sones. All air and sound ratings shall be certified by HVI.

Unit shall be U.L. and cU.L. listed.

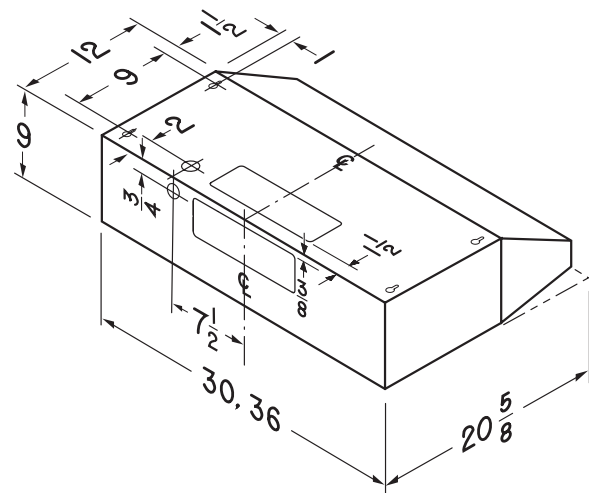

REFERENCE	QTY.	REMARKS	Project
			Location
			Architect
			Engineer
			Contractor
			Submitted by
			Date

an **SefaCo.** Store  
1-877-275-9111