

QTXE SERIES VENTILATORS

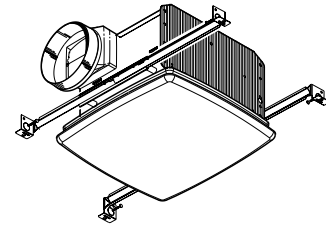

READ AND SAVE THESE INSTRUCTIONS

WARNING

TO REDUCE THE RISK OF FIRE, ELECTRIC SHOCK, OR INJURY TO PERSONS, OBSERVE THE FOLLOWING:

1. Use this unit only in the manner intended by the manufacturer. If you have questions, contact the manufacturer at the address or telephone number listed in the warranty.
2. Before servicing or cleaning unit, switch power off at service panel and lock the service disconnecting means to prevent power from being switched on accidentally. When the service disconnecting means cannot be locked, securely fasten a prominent warning device, such as a tag, to the service panel.
3. Installation work and electrical wiring must be done by a qualified person(s) in accordance with all applicable codes and standards, including fire-rated construction codes and standards.
4. Sufficient air is needed for proper combustion and exhausting of gases through the flue (chimney) of fuel burning equipment to prevent backdrafting. Follow the heating equipment manufacturer's guideline and safety standards such as those published by the National Fire Protection Association (NFPA), and the American Society for Heating, Refrigeration and Air Conditioning Engineers (ASHRAE), and the local code authorities.
5. When cutting or drilling into wall or ceiling, do not damage electrical wiring and other hidden utilities.
6. Ducted fans must always be vented to the outdoors.
7. Acceptable for use over a tub or shower when connected to a GFCI (Ground Fault Circuit Interrupter) - protected branch circuit (ceiling installation only).
8. This unit must be grounded.

CAUTION

1. For general ventilating use only. Do not use to exhaust hazardous or explosive materials and vapors.
2. To avoid motor bearing damage and noisy and/or unbalanced impellers, keep drywall spray, construction dust, etc. off power unit.
3. Please read specification label on product for further information and requirements.

CLEANING & MAINTENANCE

For quiet and efficient operation, long life, and attractive appearance - lower or remove grille and vacuum interior of unit with the dusting brush attachment.

The motor is permanently lubricated and never needs oiling. If the motor bearings are making excessive or unusual noises, replace the motor with the exact service motor. The impeller should also be replaced.

OPERATION

Use an on/off switch or speed control to operate this ventilator. See "Connect Wiring" for details.

WARRANTY

BROAN THREE YEAR LIMITED WARRANTY

Broan warrants to the original consumer purchaser of its products that such products will be free from defects in materials or workmanship for a period of three years from the date of original purchase. THERE ARE NO OTHER WARRANTIES, EXPRESS OR IMPLIED, INCLUDING, BUT NOT LIMITED TO, IMPLIED WARRANTIES OF MERCHANTABILITY OR FITNESS FOR A PARTICULAR PURPOSE.

During this three-year period, Broan will, at its option, repair or replace, without charge, any product or part which is found to be defective under normal use and service.

THIS WARRANTY DOES NOT EXTEND TO FLUORESCENT LAMP STARTERS AND TUBES. This warranty does not cover (a) normal maintenance and service or (b) any products or parts which have been subject to misuse, negligence, accident, improper maintenance or repair (other than by Broan), faulty installation or installation contrary to recommended installation instructions.

The duration of an implied warranty is limited to the three-year period as specified for the express warranty. Some states do not allow limitation on how long an implied warranty lasts, so the above limitation may not apply to you.

BROAN'S OBLIGATION TO REPAIR OR REPLACE, AT BROAN'S OPTION, SHALL BE THE PURCHASER'S SOLE AND EXCLUSIVE REMEDY UNDER THIS WARRANTY. BROAN SHALL NOT BE LIABLE FOR INCIDENTAL, CONSEQUENTIAL OR SPECIAL DAMAGES ARISING OUT OF OR IN CONNECTION WITH PRODUCT USE OR PERFORMANCE. Some states do not allow the exclusion or limitation of incidental or consequential damages, so the above limitation may not apply to you.

This warranty gives you specific legal rights, and you may also have other rights, which vary from state to state. This warranty supersedes all prior warranties.

To qualify for warranty service, you must (a) notify Broan at the address or telephone number stated below, (b) give the model number and part identification and (c) describe the nature of any defect in the product or part. At the time of requesting warranty service, you must present evidence of the original purchase date.

Installer: Leave this manual with the homeowner.

TYPICAL INSTALLATIONS

Housing mounted to I-joists.

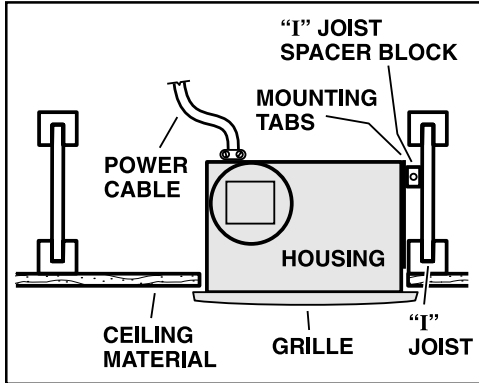

Housing mounted anywhere between trusses using hanger bars.

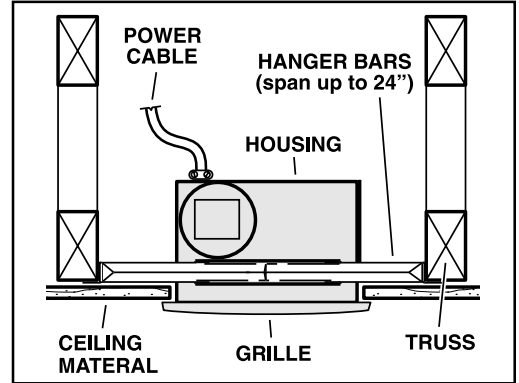

Housing mounted anywhere between I-joists using hanger bars.

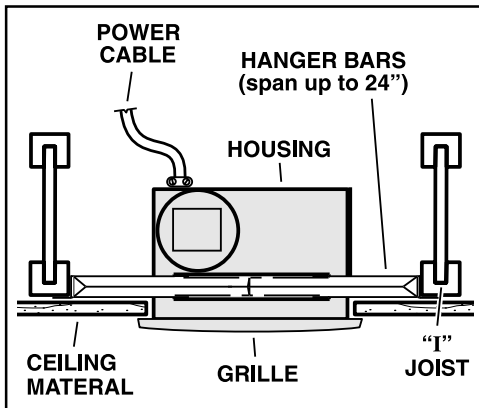

Housing mounted anywhere between trusses using hanger bars.

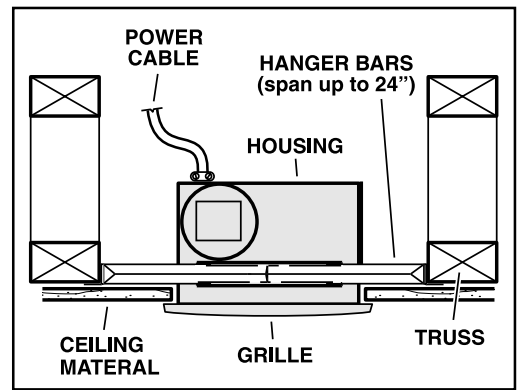

Housing mounted to joists.

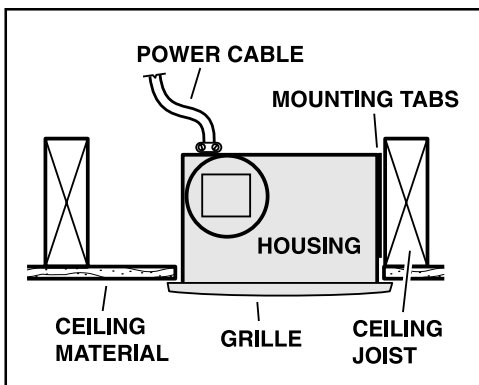

Housing mounted anywhere between joists using hanger bars.

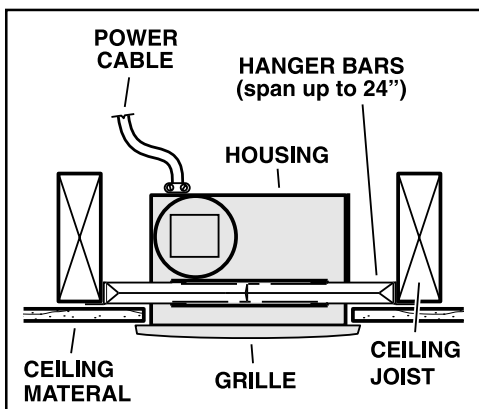

PLAN THE INSTALLATION

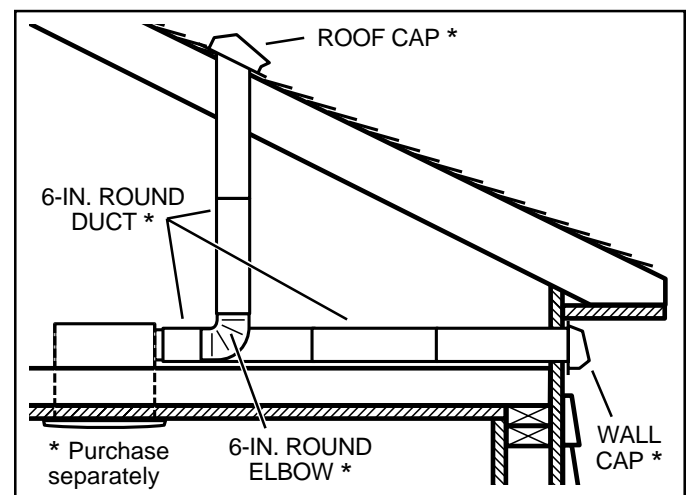

The unit will operate most quietly and efficiently when located where the shortest possible duct run and minimum number of elbows will be needed.

Use a roof cap or wall cap that has a built-in damper to reduce backdrafts.

Plan to supply the unit with proper line voltage and appropriate power cable.

INSTALL HOUSING & DUCT

1a. Mount housing to joist or I-joist.

Use a pliers to bend housing **TABS** out to 90°. Hold housing in place so that the housing tabs contact the bottom of the joist. The housing mounts with four (4) screws or nails. Screw or nail housing to joist through lowest tabs in each mounting flange, then through highest holes.

NOTE: Mounting to **I-JOIST** (shown) requires use of **SPACERS** (included) between the highest hole of each mounting flange and the I-joist.

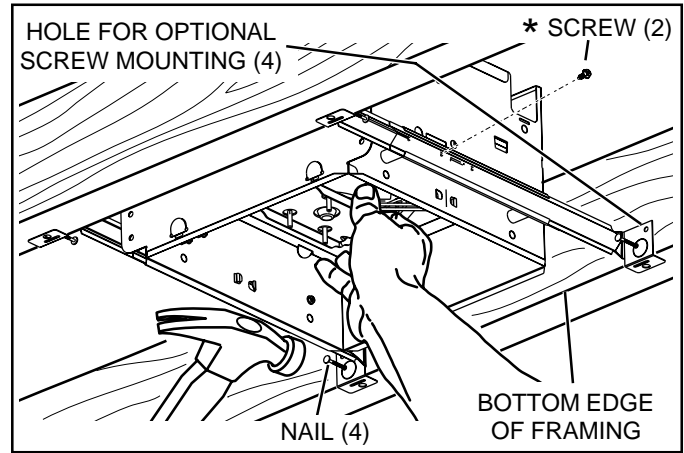
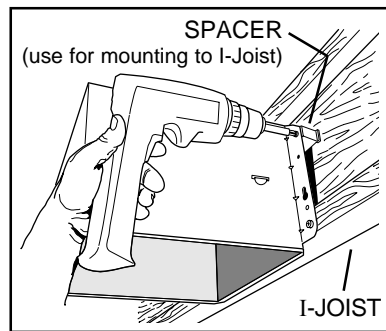
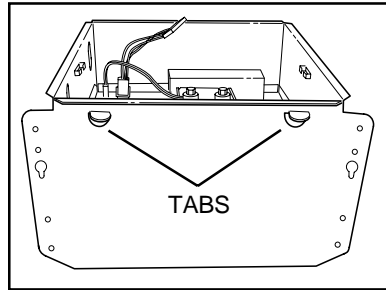

Extend **HANGER BARS** to the width of the framing.

Hold ventilator in place with the hanger bar tabs wrapping around the **BOTTOM EDGE OF THE FRAMING**.

NAIL ventilator to framing or fasten with screws (not provided) through **HOLES** near nails.

* To ensure a noise-free mount: Secure hanger bars together with **SCREWS** or use a pliers to crimp mounting channels tightly around hanger bars.

OR

1b. Mount housing anywhere between trusses, joists, or I-joists using hanger bars.

Sliding hanger bars are provided to allow for accurate positioning of housing anywhere between framing. They can be used on all types of framing (I-joist, standard joist, and truss construction) and span up to 24".

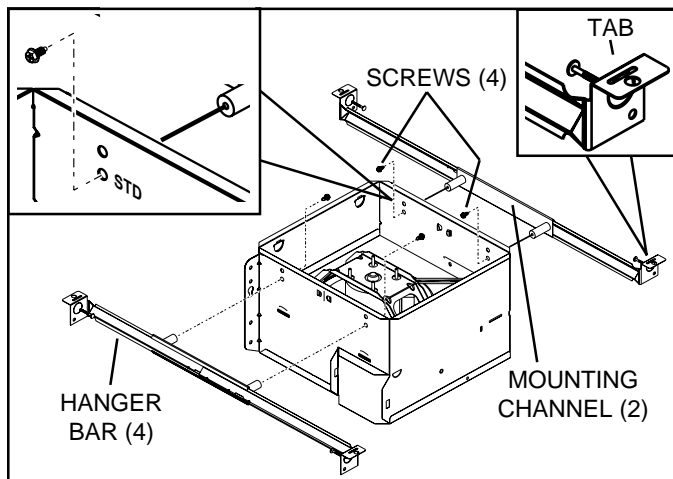

Attach the **MOUNTING CHANNELS** to the housing using the **SCREWS** supplied. Make sure **TABS** face "up" as shown. Use the set of channel mounting holes (marked "STD") to mount the housing flush with the bottom of the drywall. Use the other set of holes (not marked) to mount the housing flush with the top of the drywall.

2. Attach damper/duct connector.

Snap damper / duct connector onto housing. Make sure connector is flush with top of housing and damper flap falls closed.

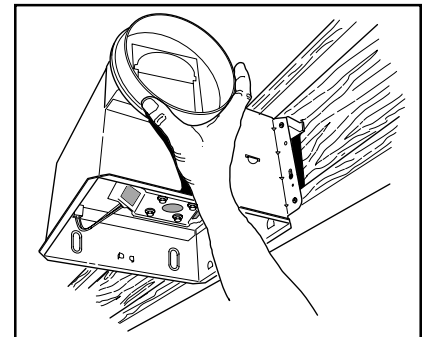

3. Install 6-inch round ductwork.

Connect 6-inch round ductwork to damper / duct connector. Run ductwork to a roof cap or wall cap. Tape all ductwork connections to make them secure and air tight.

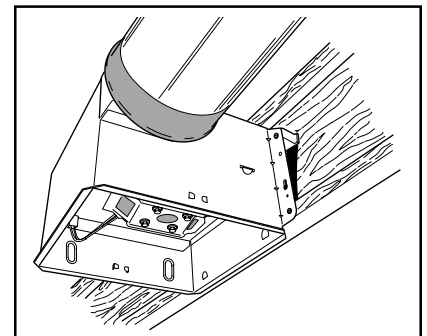

CONNECT WIRING

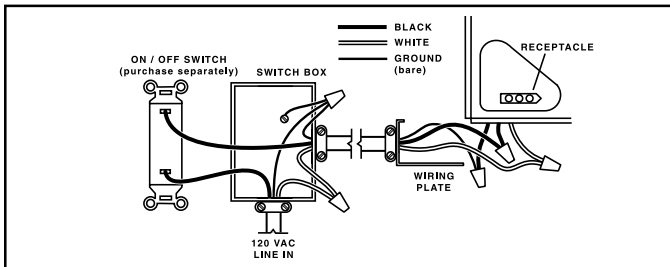
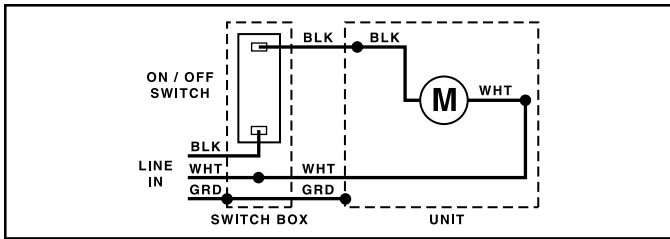

4. Connect electrical wiring.

Run 120 VAC house wiring to installation location. Use proper UL approved connector to secure house wiring to wiring plate. Connect wires as shown in wiring diagrams.

INSTALL GRILLE

5. Finish ceiling.

Install ceiling material. Cut out around housing.

6. Attach grille to housing.

Squeeze grille springs and insert them into slots on each side of housing.

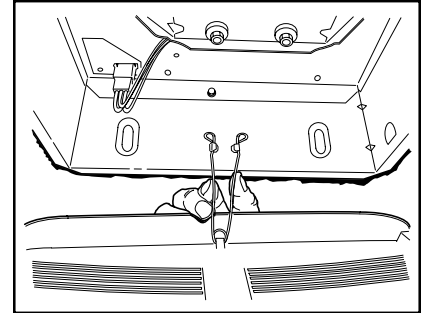

7. Push grille against ceiling.

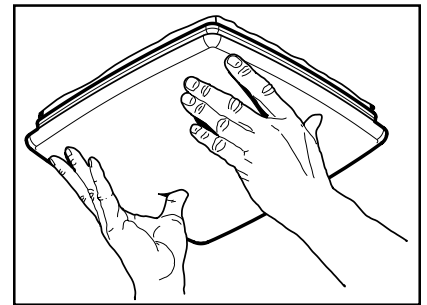

SERVICE PARTS

Key No.	Part No.	Description
1	97016466	Housing
2	97016450	Duct Connector-6"
3	98010102	Wiring Plate
4	99170245	Screw, #8-18 X .375 (2 req'd)
5	97016932	Wire Panel/Harness Assembly
6	99020284	Blower Wheel
7	99080560	Motor (QTXE050)
	99080562	Motor (QTXE080)
	99080580	Motor (QTXE110)
	99080565	Motor (QTXE150)
8	99100491	Isolator (4 req'd)
9	97016468	Motor Plate
10	99250959	Washer #8 (4 req'd)
11	99260558	Nut, Hex Lock #8-32 (4 req'd)
*	97016587	Blower Assembly (QTXE050)
*	97016588	Blower Assembly (QTXE080)
*	97016738	Blower Assembly (QTXE110)
*	97016591	Blower Assembly (QTXE150) (includes key nos. 6 thru 14)
12	99500397	Insulation (QTXE150 only)
13	99420648	Threaded Stud (QTXE150 only (4 req'd)
14	99260570	Plastic Nut (QTXE150 only) (4 req'd)
15	99140199	Grille Spring (2 req'd)
16	97016459	Grille Assembly (includes key no. 15)
17	99111293	Spacer (2 supplied)
18	QTHB1	Hanger Bar Kit

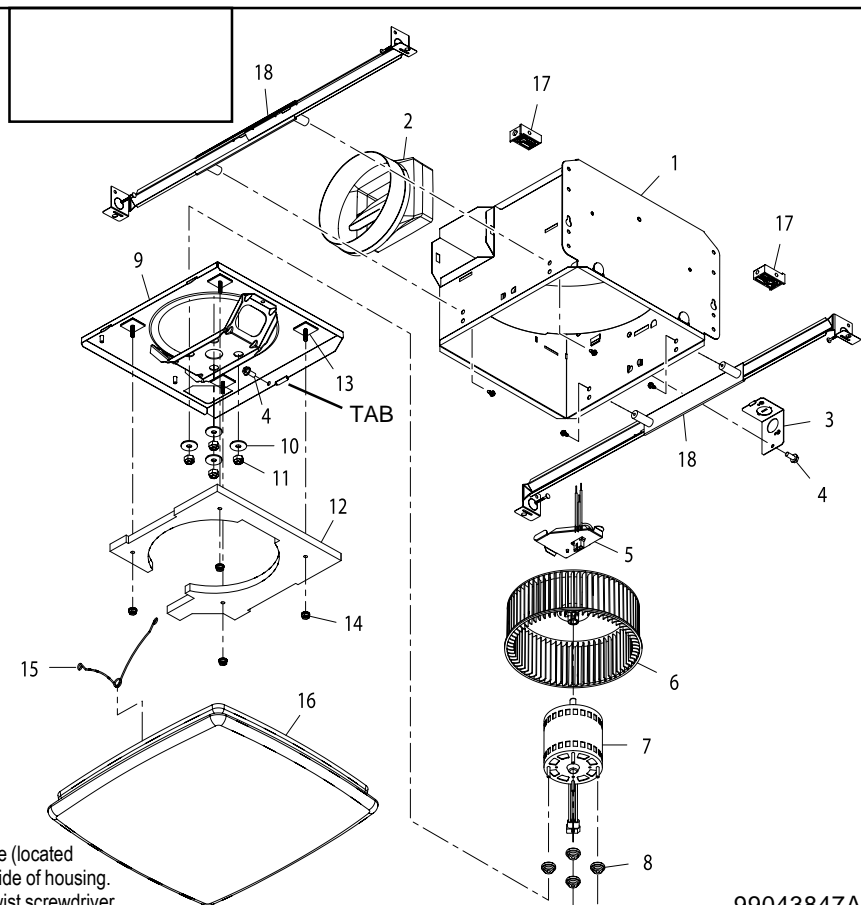

Order service parts by "Part No." - not by "Key No."

* Not shown assembled.

SERVICE NOTE To remove Blower Assembly: Unplug motor (7). Remove screw (4) from motor plate (9) flange. Find the single **TAB** on the motor plate (located next to the receptacle). Push up near motor plate tab while pushing out on side of housing. Or insert a straight-blade screwdriver into slot in housing (next to tab) and twist screwdriver.