

HUMIDITY SENSING FAN

READ AND SAVE THESE INSTRUCTIONS

WARNING

TO REDUCE THE RISK OF FIRE, ELECTRIC SHOCK, OR INJURY TO PERSONS, OBSERVE THE FOLLOWING:

1. Use this unit only in the manner intended by the manufacturer. If you have questions, contact the manufacturer at the address or telephone number listed in the warranty.
2. Before servicing or cleaning unit, switch power off at service panel and lock the service disconnecting means to prevent power from being switched on accidentally. When the service disconnecting means cannot be locked, securely fasten a prominent warning device, such as a tag, to the service panel.
3. Installation work and electrical wiring must be done by a qualified person(s) in accordance with all applicable codes and standards, including fire-rated construction codes and standards.
4. Sufficient air is needed for proper combustion and exhausting of gases through the flue (chimney) of fuel burning equipment to prevent backdrafting. Follow the heating equipment manufacturer's guideline and safety standards such as those published by the National Fire Protection Association (NFPA), and the American Society for Heating, Refrigeration and Air Conditioning Engineers (ASHRAE), and the local code authorities.
5. When cutting or drilling into wall or ceiling, do not damage electrical wiring and other hidden utilities.
6. Ducted fans must always be vented to the outdoors.
7. Acceptable for use over a tub or shower when connected to a GFCI (Ground Fault Circuit Interrupter) - protected branch circuit.
8. This unit must be grounded.

CAUTION

1. For general ventilating use only. Do not use to exhaust hazardous or explosive materials and vapors.
2. This product is designed for installation in flat ceilings only. **DO NOT MOUNT THIS PRODUCT IN A WALL.**
3. To avoid motor bearing damage and noisy and/or unbalanced impellers, keep drywall spray, construction dust, etc. off power unit.
4. Please read specification label on product for further information and requirements.

OPERATION

The humidity control and fan can be operated separately. Use a 1- or 2-function wall control. Do not use a dimmer switch to operate the humidity control. See "Connect Wiring" for details.

SENSOR OPERATION

The humidity-sensing fan uses a sophisticated humidity sensor that responds to: (a) rapid to moderate increases in humidity or (b) humidity above a set-point. The humidity sensor may occasionally turn the fan ON when environmental conditions change.

MANUAL ON WITH TIMED OFF

The humidity sensing fan has an additional operation feature. For odor or vapor control, the fan can be energized by cycling the power switch. Once the fan has been energized in this manner, it will remain on for 20 minutes.

To manually energize the fan:

1. If fan power switch is already ON, proceed to Step 2; otherwise, turn power switch ON for more than 1 second.
2. Turn fan power switch OFF for less than 1 second.
3. Turn fan power switch back ON and fan will turn ON.

CLEANING & MAINTENANCE

For quiet and efficient operation, long life, and attractive appearance - lower or remove grille and vacuum interior of unit with the dusting brush attachment.

The motor is permanently lubricated and never needs oiling. If the motor bearings are making excessive or unusual noises, replace the motor with the exact service motor. The impeller should also be replaced.

SENSOR CLEANING

The humidity sensor is mounted in the control housing. The sensor will operate most reliably when cleaned occasionally as follows:

1. Disconnect power at service entrance.
2. Remove the grille. Use a dry dustcloth, clean toothbrush, or lightly vacuum to clean sensor and grille. **DO NOT USE ABRASIVE CLOTH, STEEL WOOL PADS, OR SCOURING POWDERS.**
3. **DO NOT USE** cleaning sprays, solvents, or water on or near the sensor!

Installer: Leave this manual with the homeowner.

TYPICAL INSTALLATIONS

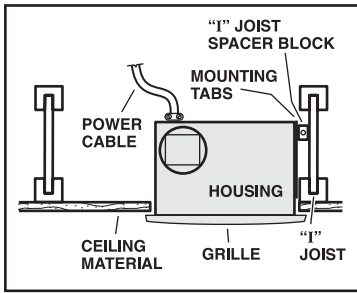

Housing mounted to I-joists.

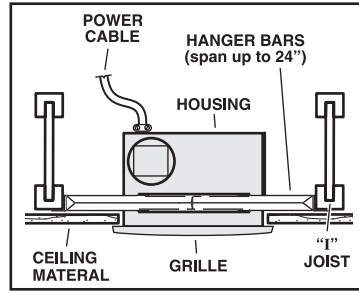

Housing mounted anywhere between I-joists using hanger bars.

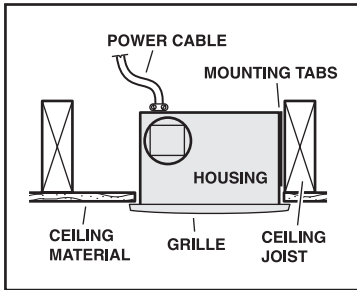

Housing mounted to joists.

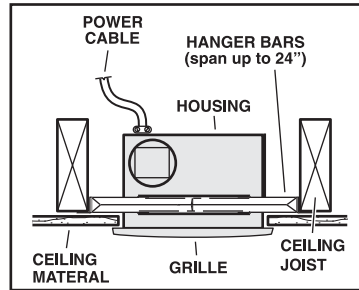

Housing mounted anywhere between joists using hanger bars.

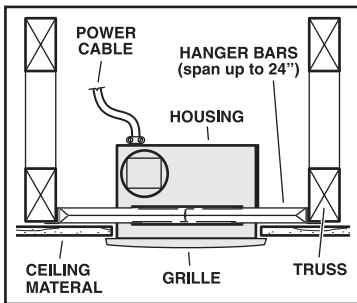

Housing mounted anywhere between trusses using hanger bars.

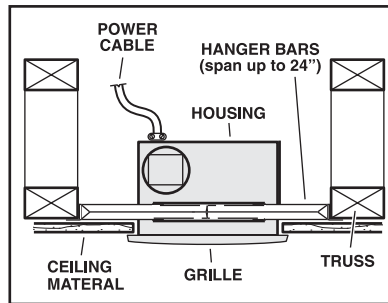

Housing mounted anywhere between trusses using hanger bars.

PLAN THE INSTALLATION

1. Choose the installation location.

The location of your humidity sensing fan is very important. Use the following guidelines for best operation:

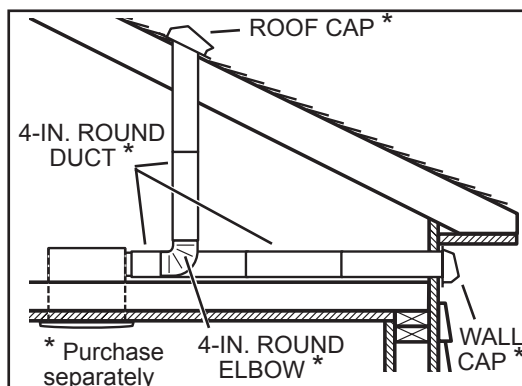

- Locate unit above (GFCI protected circuit required) or within 5 feet of shower head.
- Locate unit away from heating or cooling sources which can affect humidity levels.
- Do not locate near window. Unit may respond to the outdoor humidity level.
- Unit must be installed in ceiling to properly sense moisture.
- Locate unit only on flat ceilings up to 12 feet high for proper sensing.
- The fan will operate most efficiently when located where the shortest possible duct run and minimum number of elbows will be needed.
- Use a roof cap or wall cap that has a built-in damper to reduce backdrafts.

2. Plan the wiring.

- Plan to supply the unit with proper line voltage and appropriate power cable. Power cable should be routed to the switch box first and then to the unit (See "CONNECT WIRING" on page 3).
- Do not operate this unit with a speed control. Damage to the sensor unit will result.

INSTALL HOUSING & DUCT

1a. Mount housing to joist or I-joist.

Use a pliers to bend housing **TABS** out to 90°. Hold housing in place so that the housing tabs contact the bottom of the joist. The housing mounts with four (4) screws or nails. Screw or nail housing to joist through lowest holes in each mounting flange, then through highest holes.

NOTE: Mounting to **I-JOIST** (shown) requires use of **SPACERS** (included) between the highest hole of each mounting flange and the I-joist.

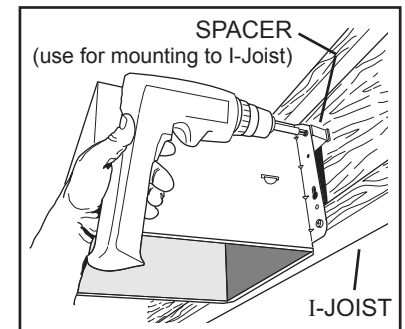
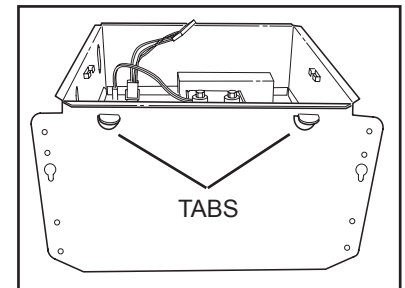

OR

1b. Mount housing anywhere between trusses, joists, or I-joists using hanger bars.

Sliding hanger bars are provided to allow for accurate positioning of housing anywhere between framing. They can be used on all types of framing (I-joist, standard joist, and truss construction) and span up to 24".

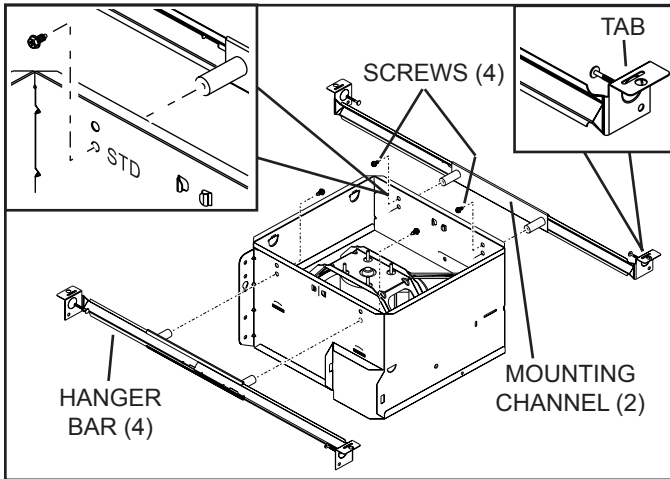

Attach the MOUNTING CHANNELS to the housing using the SCREWS supplied. Make sure TABS face "up" as shown. Use the set of channel mounting holes (marked "STD") to mount the housing flush with the bottom of the drywall. Use the other set of holes (not marked) to mount the housing flush with the top of the drywall.

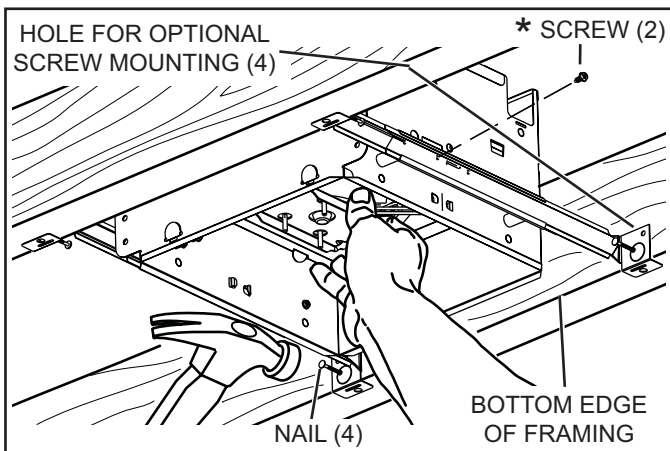

Extend HANGER BARS to the width of the framing.

Hold ventilator in place with the hanger bar tabs wrapping around the **BOTTOM EDGE OF THE FRAMING**.

NAIL ventilator to framing or fasten with screws (not provided) through HOLES near nails.

* To ensure a noise-free mount: Secure hanger bars together with SCREWS or use a pliers to crimp mounting channels tightly around hanger bars.

2. Attach damper/ duct connector.

Snap damper / duct connector onto housing. Make sure connector is flush with top of housing and damper flap falls closed.

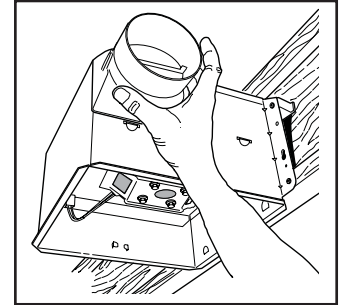

3. Install 4-inch round ductwork.

Connect 4-inch round ductwork to damper / duct connector. Run ductwork to a roof cap or wall cap. Tape all ductwork connections to make them secure and air tight.

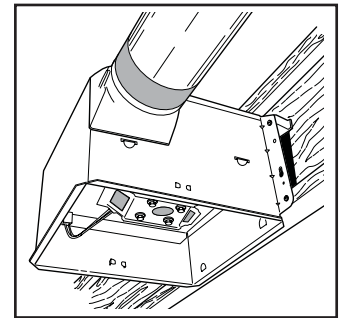

CONNECT WIRING

WIRING OPTION #1 - Allows fan to operate in automatic mode or manual mode (for odor control) by cycling ON/OFF switch.

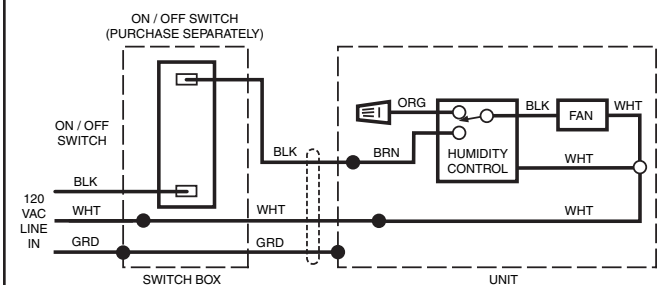

WIRING OPTION #2 - Fan can be turned ON, OFF, or set to operate automatically.

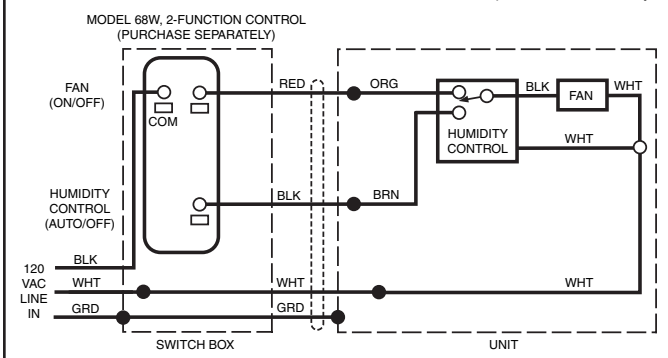

4. Connect electrical wiring.

Run 120 VAC house wiring to installation location. Use proper UL approved connector to secure house wiring to wiring plate. Connect wires as shown in wiring diagrams.

INSTALL GRILLE

6. Finish ceiling.

Install ceiling material. Cut out around housing.

7. Attach grille to housing.

Squeeze grille springs and insert them into slots on each side of housing.

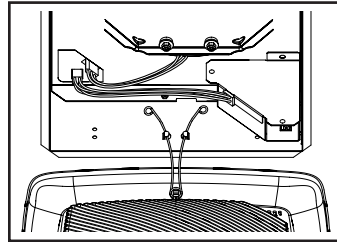

8. Push grille against ceiling.

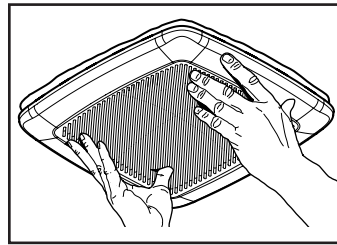

WARRANTY

BROAN THREE YEAR LIMITED WARRANTY

Broan warrants to the original consumer purchaser of its products that such products will be free from defects in materials or workmanship for a period of three years from the date of original purchase. THERE ARE NO OTHER WARRANTIES, EXPRESS OR IMPLIED, INCLUDING, BUT NOT LIMITED TO, IMPLIED WARRANTIES OF MERCHANTABILITY OR FITNESS FOR A PARTICULAR PURPOSE.

During this three-year period, Broan will, at its option, repair or replace, without charge, any product or part which is found to be defective under normal use and service.

THIS WARRANTY DOES NOT EXTEND TO FLUORESCENT LAMP STARTERS AND TUBES. This warranty does not cover (a) normal maintenance and service or (b) any products or parts which have been subject to misuse, negligence, accident, improper maintenance or repair (other than by Broan), faulty installation or installation contrary to recommended installation instructions.

The duration of an implied warranty is limited to the three-year period as specified for the express warranty. Some states do not allow limitation on how long an implied warranty lasts, so the above limitation may not apply to you.

BROAN'S OBLIGATION TO REPAIR OR REPLACE, AT BROAN'S OPTION, SHALL BE THE PURCHASER'S SOLE AND EXCLUSIVE REMEDY UNDER THIS WARRANTY. BROAN SHALL NOT BE LIABLE FOR INCIDENTAL, CONSEQUENTIAL OR SPECIAL DAMAGES ARISING OUT OF OR IN CONNECTION WITH PRODUCT USE OR PERFORMANCE. Some states do not allow the exclusion or limitation of incidental or consequential damages, so the above limitation may not apply to you.

This warranty gives you specific legal rights, and you may also have other rights, which vary from state to state. This warranty supersedes all prior warranties.

To qualify for warranty service, you must (a) notify Broan at the address or telephone number stated below, (b) give the model number and part identification and (c) describe the nature of any defect in the product or part. At the time of requesting warranty service, you must present evidence of the original purchase date.

SERVICE PARTS

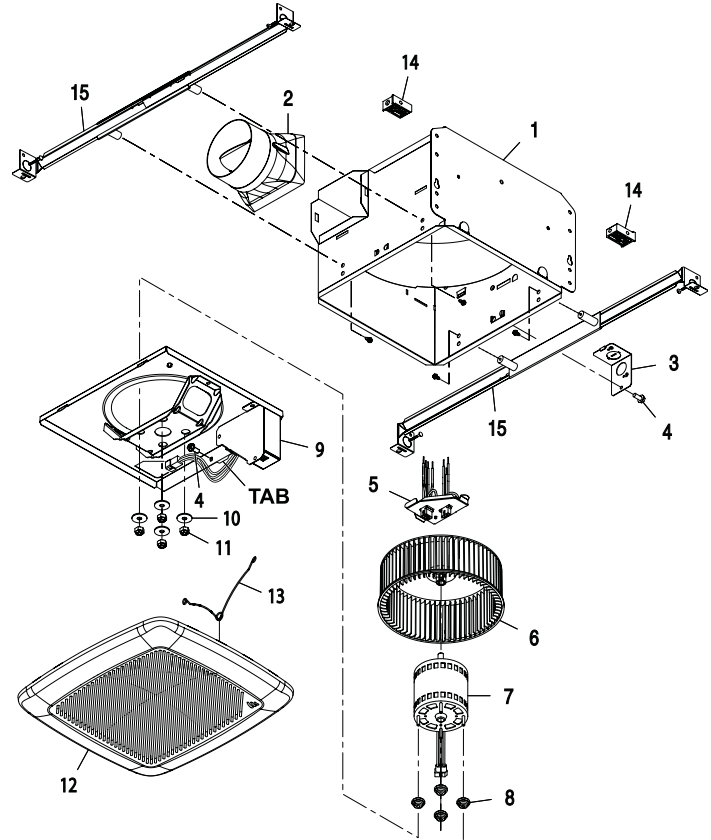

Replacement parts can be ordered on our website. Please visit us at www.broan.com

SERVICE NOTE

To remove Blower Assembly: Unplug motor (7). Remove screw (4) from motor plate (9) flange. Find the single TAB on the motor plate (located next to the receptacle). Push up near motor plate tab while pushing out on side of housing. Or insert a straight-blade screwdriver into slot in housing (next to tab) and twist screwdriver.

Key No.	Part No.	Description
1	97016466	Housing
2	97016449	Duct Connector - 4"
3	98010102	Wiring Plate
4	99170245	Screw, #8-18 X .375 (2 req'd)
5	97017086	Wire Panel/Harness Assembly
6	99020284	Blower Wheel
7	99080580	Motor
8	99100491	Isolator (4 req'd)
9	97017478	Motor Plate & Control Assembly
10	99250959	Washer #8 (4 req'd)
11	99260558	Nut, Hex Lock #8-32 (4 req'd)
*	97017087	Blower Assembly (includes key nos. 6 thru 11)
12	97017420	Grille Assembly (includes key nos. 13 & 16)
13	99140199	Grille Spring (2 req'd)
14	99111293	Spacer (2 supplied)
15	SQTHB1	Hanger Bar Kit

Order service parts by "Part No." - not by "Key No."