

QTR / QTRE SERIES FANS

MODELS QTR050F, QTR080, QTR110, QTRE080, QTRE110

Ultra-quiet, high performance bath fan with a modern-styled grille.

FEATURES

BLOWER:

- Plug-in, permanently lubricated motor - engineered for continuous operation
- Dynamically balanced centrifugal blower wheel for quiet, efficient performance
- Low RPM for quiet operation
- Resilient anti-vibration motor mounts

HOUSING:

- Rugged, 26 gauge, galvanized steel construction
- Polymeric, 4" round duct connector with tapered sleeve and no metallic clatter
- 7-5/8" height allows for 2" x 8" (nominal) joist installations
- Sturdy, easy, four-point mounting directly to joist
- Includes unique spacer (patent pending) for mounting to engineered "I" joists
- Includes hanger bars to position housing anywhere between 16" to 24"-on-center joists (Models QTRE080 & QTRE110 only)
- Two sets of mounting holes for hanger bars allow flush installation with bottom or top of drywall (Models QTRE080 & QTRE110 only)

GRILLE:

- Polymeric construction
- Innovative design - the result of extensive research with designers and consumers

BUILDER PACKS:

- Broan Model QTR050F
 - Includes blower and grille only (packed 1 per carton)
- Rough-in housing required - order Broan Model QTXR000HF (4 housings per carton)
 - Includes hanger bars to position housing anywhere between 16" to 24"-on-center joists (4 sets of hangers per carton)
 - Two sets of mounting holes for hanger bars allow flush installation with bottom or top of drywall

CONTROLS (Purchase separately):

- Model 69VL (Ivory) / 69WL (White) - One rocker switch with "on" indicator light
- Other controls available from Broan-NuTone

U.L. Listed for use over bathtubs and showers when connected to a GFCI protected branch circuit (ceiling mount only).

3-Year Warranty

TYPICAL SPECIFICATION

Ceiling Ventilator shall be Broan Model QTR050F (QTR080) (QTR110) (QTRE080) (QTRE110).

Ceiling Ventilator shall have corrosion resistant galvanized steel housing with four-point mounting capability. It shall be ducted to a roof or wall cap using 4" round ductwork.

Blower assembly shall be removable, have a centrifugal-type blower wheel and a permanently lubricated motor designed for continuous operation and mounted with resilient anti-vibration mounts.

Non-metallic damper/duct connector shall be included.

Air delivery shall be no less than 50 (80) (110) CFM and sound level no greater than 0.4 (0.8) (1.0) (1.3) (1.5) Sones. All air and sound ratings shall be certified by HVI.

Ceiling ventilator shall be Energy Star® qualified and have an energy efficient permanent split capacitor motor (Models QTRE080 & QTRE110 only).

Ceiling Ventilator shall be U.L. Listed for use over bathtubs and showers when connected to a GFCI protected branch circuit.

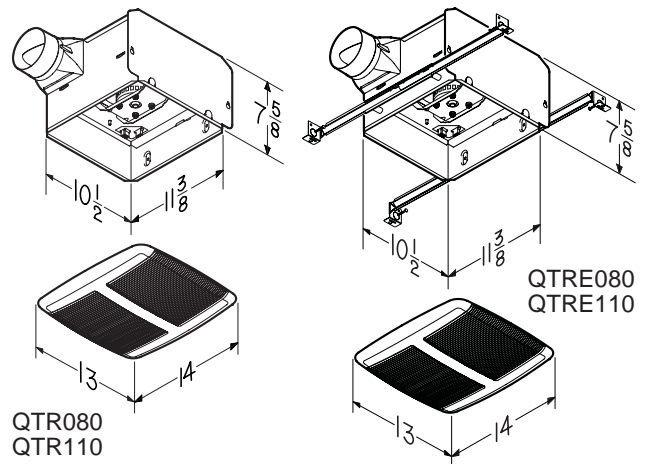

Models QTRE080 & QTRE110 only

REFERENCE	QTY.	REMARKS	Project
			Location
			Architect
			Engineer
			Contractor
			Submitted by Date

HVI PERFORMANCE

Model	Sones @0.1" Ps	CFM @0.1" Ps
QTR050F	0.4	50
QTR080	1.0	80
QTR110	1.5	110
QTRE080	0.8	80
QTRE110	1.3	110



HVI-2100 CERTIFIED RATINGS comply with new testing technologies and procedures prescribed by the Home Ventilating Institute, for off-the-shelf products, as they are available to consumers. Product performance is rated at 0.1 in. static pressure, based on tests conducted in AMCA's state-of-the-art test laboratory. Sones are a measure of humanly-perceived loudness, based on laboratory measurements.

AMPS

Model	Amps
QTR050F	0.3
QTR080	0.7
QTR110	0.9
QTRE080	0.4
QTRE110	0.4

WEIGHT

Model	Shipping Weight
QTR050F	7.8 lbs.
QTR080	12.4 lbs.
QTR110	12.4 lbs.
QTRE080	11.8 lbs.
QTRE110	11.8 lbs.



Models QTRE080 & QTRE110 only

AIR FLOW PERFORMANCE

MODEL QTR050F

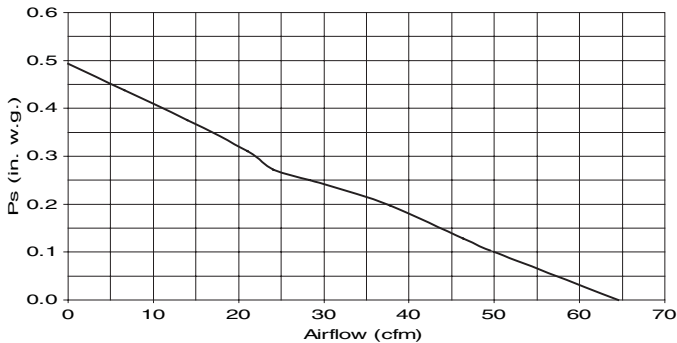

AIR FLOW PERFORMANCE

MODEL QTR080

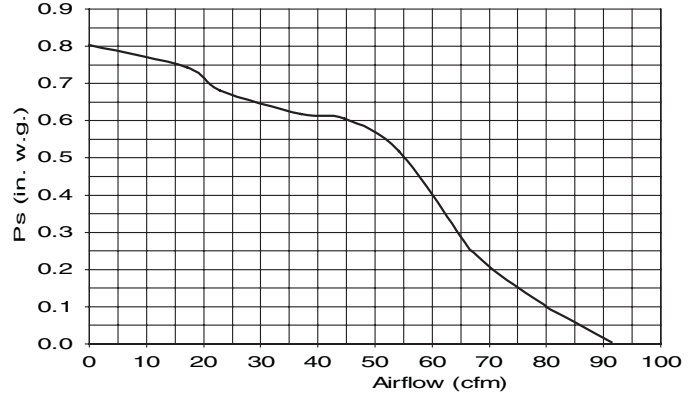

MODEL QTR110

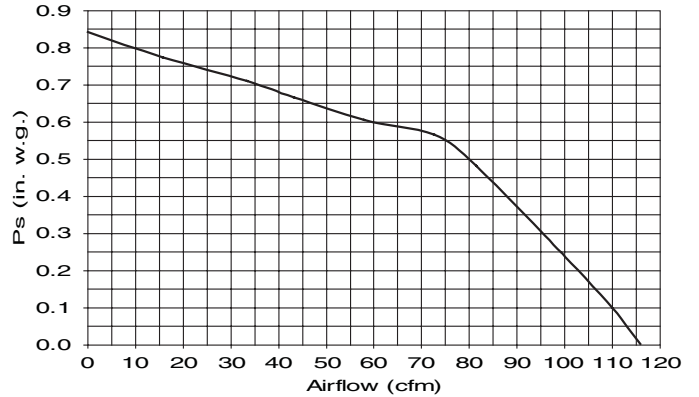

MODEL QTRE080

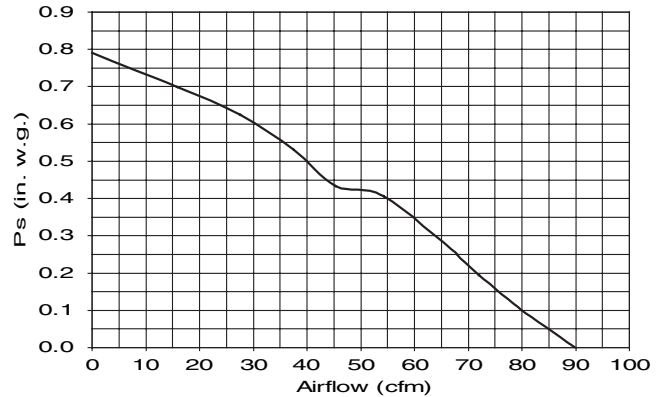

MODEL QTRE110

