

# RECESSED FAN / LIGHT

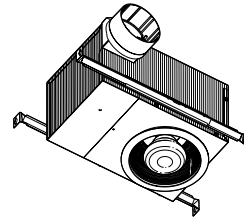

## READ AND SAVE THESE INSTRUCTIONS

### WARNING

#### TO REDUCE THE RISK OF FIRE, ELECTRIC SHOCK, OR INJURY TO PERSONS, OBSERVE THE FOLLOWING:

1. Use this unit only in the manner intended by the manufacturer. If you have questions, contact the manufacturer at the address or telephone number listed in the warranty.
2. Before servicing or cleaning unit, switch power off at service panel and lock the service disconnecting means to prevent power from being switched on accidentally. When the service disconnecting means cannot be locked, securely fasten a prominent warning device, such as a tag, to the service panel.
3. Installation work and electrical wiring must be done by a qualified person(s) in accordance with all applicable codes and standards, including fire-rated construction codes and standards.
4. Sufficient air is needed for proper combustion and exhausting of gases through the flue (chimney) of fuel burning equipment to prevent backdrafting. Follow the heating equipment manufacturer's guideline and safety standards such as those published by the National Fire Protection Association (NFPA), and the American Society for Heating, Refrigeration and Air Conditioning Engineers (ASHRAE), and the local code authorities.
5. When cutting or drilling into wall or ceiling, do not damage electrical wiring and other hidden utilities.
6. Ducted fans must always be vented to the outdoors.
7. If this unit is to be installed over a tub or shower, it must be marked as appropriate for the application and be connected to a GFCI (Ground Fault Interrupter) - protected branch circuit.
8. Never place a switch where it can be reached from a tub or shower.
9. Install this unit in a flat ceiling only.
10. For use in non fire rated installations only.
11. Not for use in environmental air handling spaces.
12. **CAUTION - RISK OF FIRE: 75W MAX. LAMP.** Use R30, BR30, or PAR30L lamps only (75W Max.). For wet locations (tub or shower) - use PAR30L (75W Max.) lamp only. **Use no other lamp types.** Do not install a lamp indented for use only in enclosed luminaries.
13. This unit must be grounded.

### CAUTION

1. For general ventilating use only. Do not use to exhaust hazardous or explosive materials and vapors.
2. To avoid motor bearing damage and noisy and/or unbalanced impellers, keep drywall spray, construction dust, etc. off power unit.
3. Please read specification label on product for further information and requirements.

### OPERATION

The fan and light can be operated using various combinations of on/off switches and solid-state variable speed controls:

- Fan and light controlled with single on/off switch
- Fan and light controlled with separate on/off switches
- Fan controlled with on/off switch - light with dimmer switch

Do not use a speed control to operate the fan in this unit.

See "Connect Wiring" section for various wiring options.

### CLEANING

**To clean trim ring / baffle:** Vacuum with a soft brush attachment or remove trim ring / baffle and clean with a soft cloth and mild soap or detergent. Dry thoroughly before reinstalling.

**To clean inside of housing:** Remove trim ring / baffle and vacuum inside of housing with a soft brush attachment.

### MAINTENANCE

Motor is permanently lubricated. Do not oil or disassemble motor.

See "Service Parts" section for a list and illustrations of service parts.

### WARRANTY

#### BROAN-NUTONE ONE YEAR LIMITED WARRANTY

Broan-NuTone warrants to the original consumer purchaser of its products that such products will be free from defects in materials or workmanship for a period of one year from the date of original purchase. THERE ARE NO OTHER WARRANTIES, EXPRESS OR IMPLIED, INCLUDING, BUT NOT LIMITED TO, IMPLIED WARRANTIES OF MERCHANTABILITY OR FITNESS FOR A PARTICULAR PURPOSE.

During this one-year period, Broan-NuTone will, at its option, repair or replace, without charge, any product or part which is found to be defective under normal use and service. THIS WARRANTY DOES NOT EXTEND TO FLUORESCENT LAMP STARTERS AND TUBES. This warranty does not cover (a) normal maintenance and service or (b) any products or parts which have been subject to misuse, negligence, accident, improper maintenance or repair (other than by Broan-NuTone), faulty installation or installation contrary to recommended installation instructions.

The duration of an implied warranty is limited to the one-year period as specified for the express warranty. Some states do not allow limitation on how long an implied warranty lasts, so the above limitation may not apply to you.

BROAN-NUTONE'S OBLIGATION TO REPAIR OR REPLACE, AT BROAN-NUTONE'S OPTION, SHALL BE THE PURCHASER'S SOLE AND EXCLUSIVE REMEDY UNDER THIS WARRANTY. BROAN-NUTONE SHALL NOT BE LIABLE FOR INCIDENTAL, CONSEQUENTIAL OR SPECIAL DAMAGES ARISING OUT OF OR IN CONNECTION WITH PRODUCT USE OR PERFORMANCE. Some states do not allow the exclusion or limitation of incidental or consequential damages, so the above limitation may not apply to you.

This warranty gives you specific legal rights, and you may also have other rights, which vary from state to state. This warranty supersedes all prior warranties.

To qualify for warranty service, you must (a) notify Broan-NuTone at the address or telephone number stated below, (b) give the model number and part identification and (c) describe the nature of any defect in the product or part. At the time of requesting warranty service, you must present evidence of the original purchase date.

**Installer: Leave this manual with the homeowner.**

## PLAN THE INSTALLATION

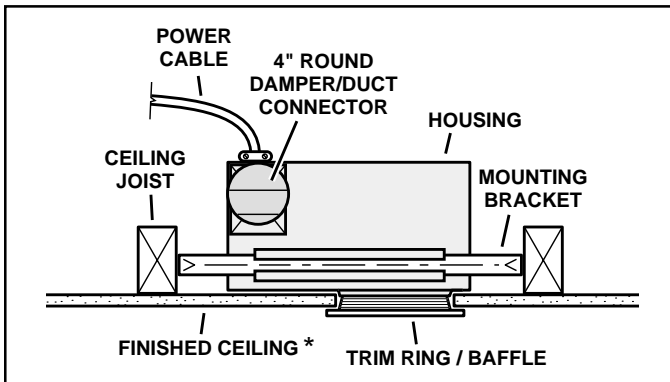

*Typical Installation*

The unit can be installed anywhere between ceiling joists using mounting brackets provided.

\* Install in a flat ceiling only.

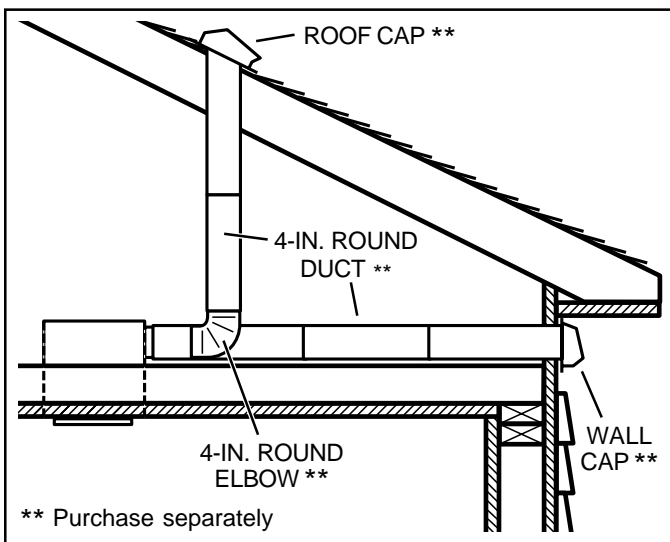

*Two of the most common ways to connect ductwork to the unit.*

The unit will operate most quietly and efficiently when located where the shortest possible duct run and minimum number of elbows will be needed.

Plan to supply the unit with proper line voltage and appropriate power cable.

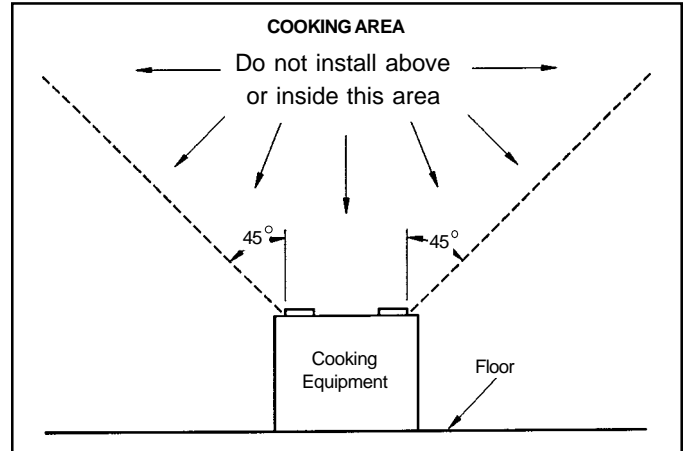

*Do not install in a cooking area.*

The unit must not be installed above or inside the cooking area shown.

## INSTALLATION

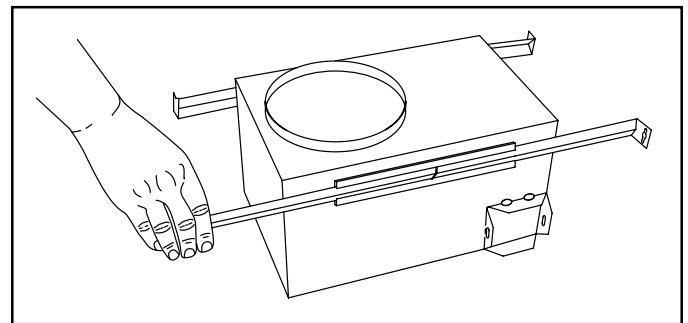

### 1. Install mounting brackets.

Slide the adjustable mounting brackets into the bracket channels on the housing.

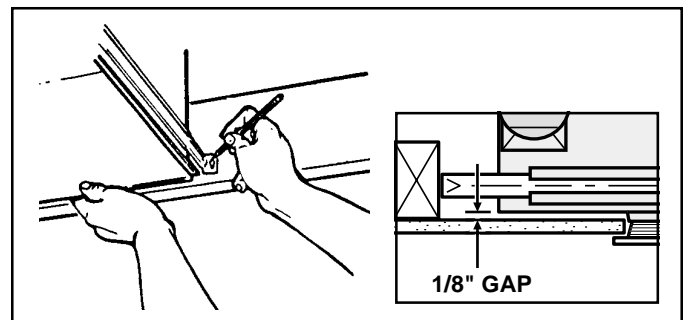

### 2. Mark mounting location.

Position unit between joists and extend mounting brackets. **IMPORTANT: Position brackets so there will be an 1/8" gap between bottom of housing and ceiling material.** Mark the top of keyhole slot on all four mounting brackets.

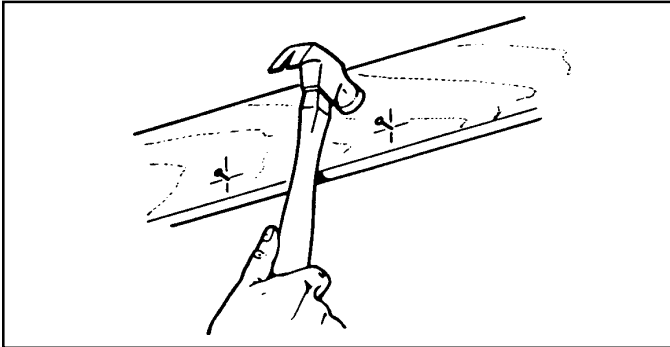

### 3. Pound in nails.

Remove unit temporarily, and pound nails partially into joists at all four marked locations.

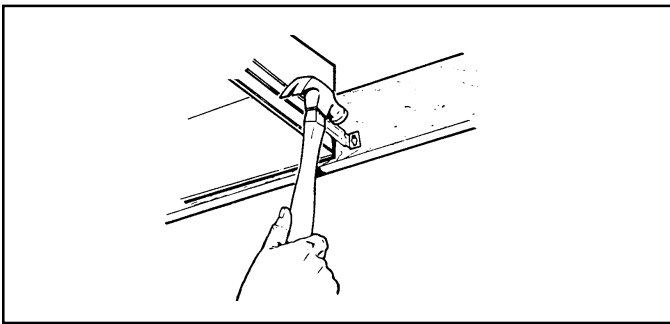

### 4. Hang and secure housing.

Hang unit from nails. Check to make sure that there will be a 1/8" gap between bottom of housing and ceiling material. Pound nails tight. For wide joist centers: A #8 x 3/8 self-tapping screw can be used to join extended brackets together and create a rigid mount. To ensure a noise-free mount, crimp the bracket channels tightly around mounting brackets.

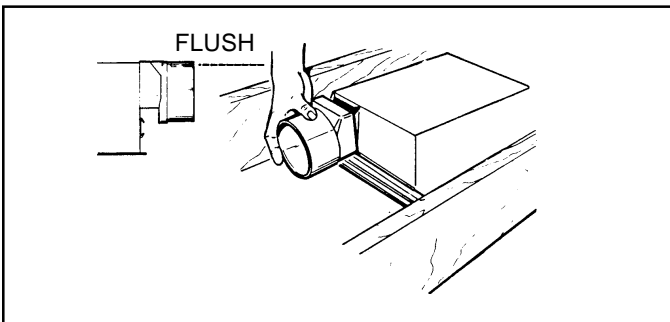

### 5. Attach damper/duct connector.

Snap the damper/duct connector onto housing. Make sure that tabs on the connector lock in housing slots. (Top of damper/duct connector will be flush with top of housing.)

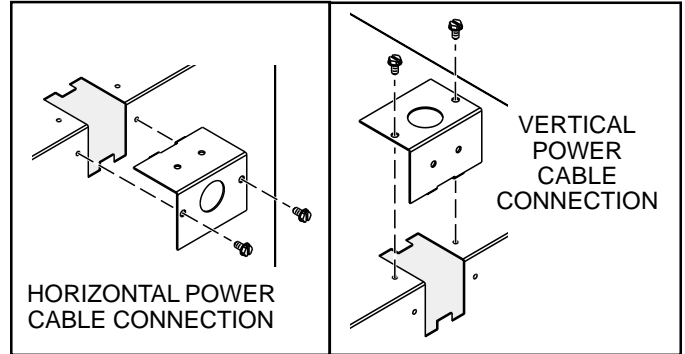

### 6. Choose power cable direction.

Remove wiring plate. When re-attached, the wiring plate allows the power cable to enter unit horizontally or vertically.

### 7. Connect wiring.

Unit can be wired from outside of housing as shown. Use UL approved connectors to wire per local codes.

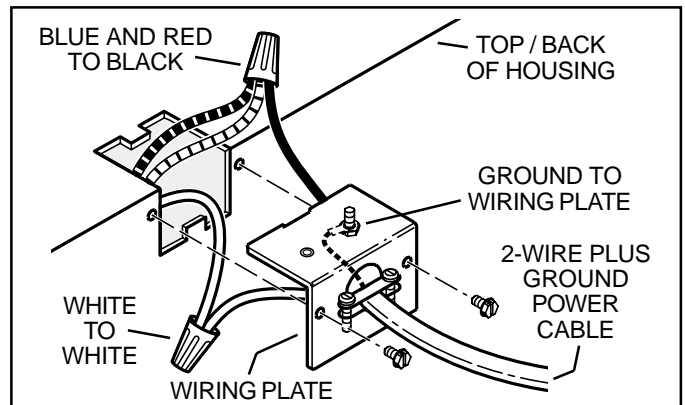

*Fan and Light operated with single on/off switch*

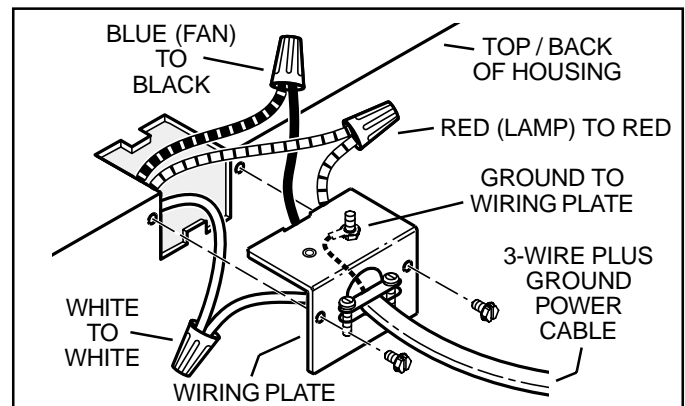

*Fan operated with separate on/off switch.  
Light operated with separate on/off switch  
or dimmer switch.*

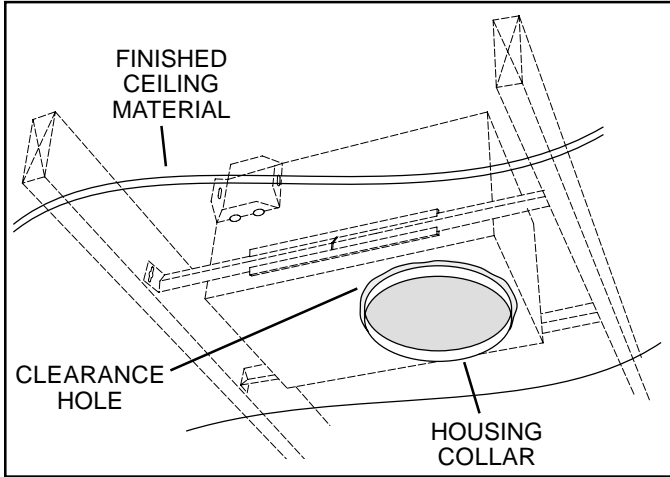

### 8. Finish ceiling.

Cut an opening in finished ceiling material for housing collar.

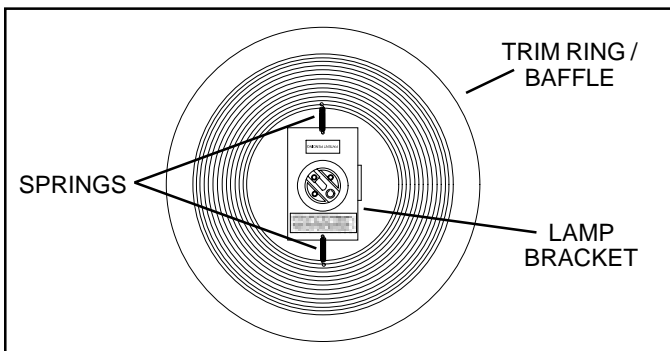

### 9. Attach trim ring / baffle to housing.

Insert one end of each spring into the holes on the lamp bracket. Center trim ring / baffle in ceiling opening.

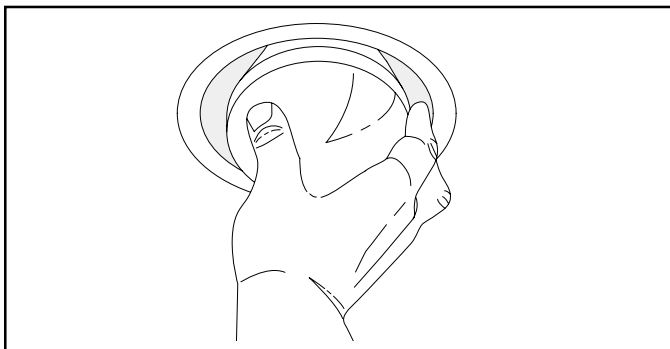

### 10. Install bulb.

**CAUTION - RISK OF FIRE:**  
**75W MAX. LAMP**

Use R30, BR30, or PAR30L lamps only (75W Max.).

For wet locations (tub or shower) - use PAR30L (75W Max.) lamp only. **Use no other lamp types.**

Do not install a lamp indented for use only in enclosed luminaries.

## SERVICE PARTS

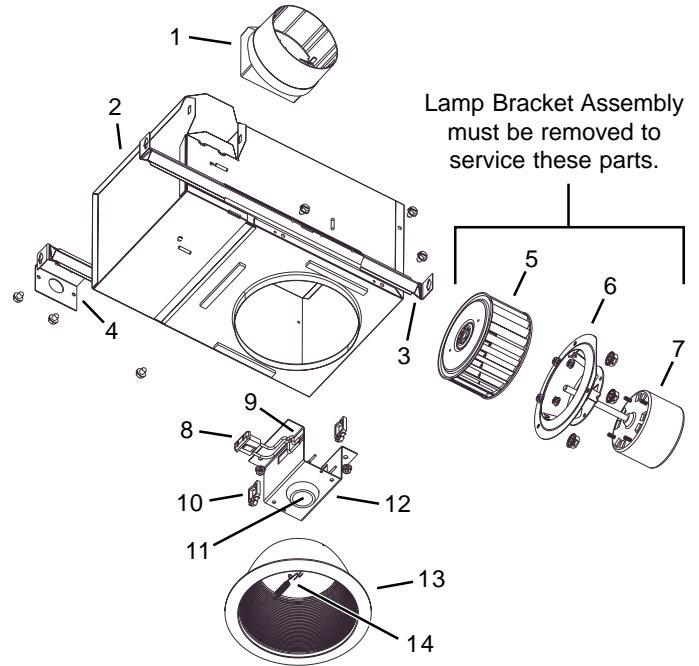

KEY NO.	PART NO.	DESCRIPTION
1	97014185	Damper / Duct Connector
2	97016382	Housing Assembly
3	98003036	Mounting Bracket (4 req.)
4	98005512	Wiring Adaptor Plate
5	99524804	Blower Wheel *
6	99524805	Motor Bracket / Venturi *
7	99080557	Motor *
	97016454	Motor / Motor Bracket Assembly (includes Key Nos. 6 & 7) *
8	99270835	Receptacle
9	99271322	Thermal Protector
10	99420551	Plastic Wire Clip
11	99770033	Lamp Socket
12	97016491	Lamp Bracket
	97016453	Lamp Bracket Assembly (includes Key Nos. 8 thru 12)
13	99524802	Trim Ring / Baffle with Springs
14	99524803	Baffle Springs (2 req.)

Order replacement parts by PART NO. - not by KEY NO.

\* Lamp Bracket Assembly must be removed to service these parts.