

# ROOF MOUNTED POWERED ATTIC VENTILATORS

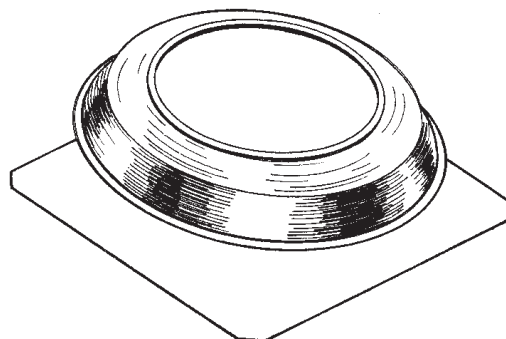

Powerful and easy to install, these units supplement or replace air conditioning by removing the blanket of hot, trapped air from attics - automatically.

### FEATURES

- Precision balanced 14" metal blade for maximum air flow - minimum sound level
- PVC plastic dome provides ultraviolet protection and superior durability (Models 350, 355, 356)
- .050 aluminum dome (Model 358)
- 23 gage metal flashing - allows for nailing and hot tar application
- Mesh bird screen
- Built-in adjustable thermostat - for automatic operation at your chosen temperature level
- Thermally protected, permanently lubricated motor
- Mounts easily between rafters - installation template included

### CONTROLS DESIGNED FOR USE WITH THESE PRODUCTS

(purchase separately):

- Model 69V (Ivory)/69W (White) Single-Function Control
- Model 68V (Ivory)/68W (White) Two-Function Control
- Model 72V (Ivory)/72W (White) Electronic Variable Speed Control- 6 amp (not for use with Model 356)

### SPECIFICATIONS

| MODEL | VOLTS | AMPS | RPM  | CFM  | ATTIC<br>MAX. SQ. FT. | MIN.<br>INLET AREA |
|-------|-------|------|------|------|-----------------------|--------------------|
| 350   | 120   | 3.6  | 1000 | 1050 | 1500                  | 3.5 SQ. FT.        |
| 355   | 120   | 4.3  | 1050 | 1200 | 1715                  | 4.0 SQ. FT.        |
| 356   | 120   | 8.0  | 1500 | 1600 | 2285                  | 5.5 SQ. FT.        |
| 358   | 120   | 4.3  | 1050 | 1200 | 1715                  | 4.0 SQ. FT.        |



HVI-2100 CERTIFIED RATINGS comply with new testing technologies and procedures prescribed by the Home Ventilating Institute, for off-the-shelf products, as they are available to consumers. Product performance is rated at 0.1 in. static pressure, based on tests conducted in AMCA's state-of-the-art test laboratory. Sones are a measure of humanly-perceived loudness, based on laboratory measurements.



### TYPICAL SPECIFICATION

Roof Mounted Attic Ventilator shall be Broan Model 350 (355) (356) (358).

Ventilator shall have metal blade and flashing plate. Bird screen to be included.

Dome to be ultraviolet resistant plastic. (.050 Approx. 18 gage aluminum). Motor to be thermally protected and permanently lubricated. RPM not to exceed 1000 (Model 350), 1100 (Models 355 and 358), 1500 (Model 356).

Ventilator shall have a built-in adjustable thermostat and mount easily between rafters or wall studs.

Air delivery shall be no less than 1050 CFM (Model 350), 1200 CFM (Models 355 and 358), 1600 CFM (Model 356). All ratings shall be certified by HVI. Units to be U.L. Listed.

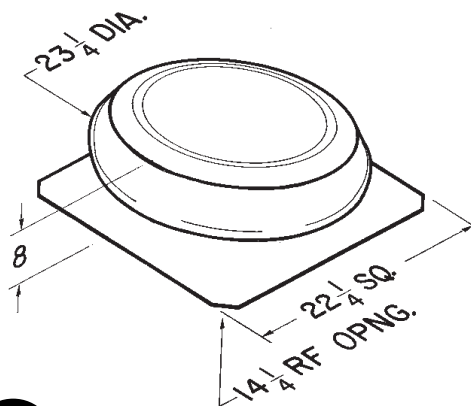

| REFERENCE | QTY. | REMARKS | Project      |      |
|-----------|------|---------|--------------|------|
|           |      |         | Location     |      |
|           |      |         | Architect    |      |
|           |      |         | Engineer     |      |
|           |      |         | Contractor   |      |
|           |      |         | Submitted by | Date |