

Air-King[®]

Ventilation Products

SPECIFICATIONS
EWF-180
EXHAUST FANS

180 CFM/6.5 SONES @ 0.10" WG. -HVI CERTIFIED
120 Volts, .80 amps, 60 hz.

- **Grill**
White polymeric grill, dimensions - 11¹/₂" x 11¹/₂".
- **Blower Wheel**
One piece polymeric wheel, 5¹/₈" diameter, 2³/₈" wide, 48 fins.
- **Motor**
Heavy duty, permanently split capacitor, plug-in, 4 pole motor, life time lubrication, thermally protected. Rated 120 volts, 60 hz., 0.80 amps.
- **Fan Housing**
-
- **Duct**
Metal 8" round duct, vents directly to outside, includes springloaded aluminum backdraft damper.
- **Unit Mounting**
-
- **Ventilating Area**
For rooms up to 225 sq. ft.
- **Single Pack Shipping Info**
Box Dim: -
UPC: 0-8316221801-8

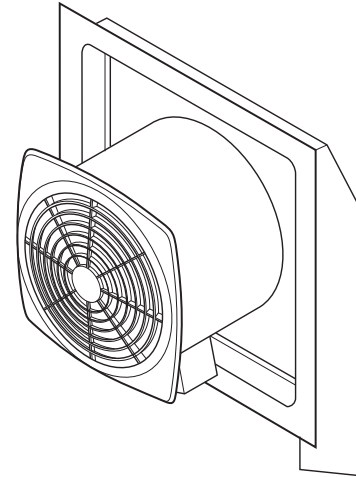

CUL/HVI

HVI PERFORMANCE									
Static Pressure (inches of w.g.)	0	0.05	0.1	0.15	0.2	0.25	0.3	0.35	0.4
CFM	-	-	-	-	-	-	-	-	-
RPM	-	-	-	-	-	-	-	-	-
WATTS	-	-	-	-	-	-	-	-	-

Air-King exhaust fans are tested by the Air Movement and Control Association (AMCA) in accordance with HVI test standard 916, (Air Flow Test Standard) and HVI test standard 915 (Procedure For Loudness Rating Of Residential Fan Products). The Performance results are certified and verified by the Home Ventilating Institute (HVI).