

Barcelona Collection

500 CFM Island Range Hood, 120 Volts, 2.8 amps, 60 hz.

➤ **DIMENSIONS**

Overall bottom projection - 23^{5/8}"
 Height (Less Ducting) - 11"
 Available widths - 35^{1/2}"

➤ **HOOD BODY**

All metal cold rolled or stainless, finished in powder coat paint or brushed stainless.

➤ **MOTOR**

High quality, efficient, permanently split capacitor motor. Rated 120 Volts, 2.8 Amps.

➤ **BLOWER WHEEL**

Dual inlet, electronically balanced polymeric centrifugal blower wheel. 5^{7/32}" width
 59 paddles.

➤ **LIGHTING**

2 - fully enclosed 40 watt maximum candelabra bulbs.

➤ **DUCTING OPTIONS**

Vertical - 6" round duct adapter complete with polymeric back draft damper ensuring quiet operation.

➤ **FILTERS**

Grease filter RF76, dishwasher safe, 4 per unit

➤ **MOUNTING**

Ceiling mounted using supplied template. 6" round ducting enclosed in metallic tubing. Install a min. 22" to 25" from the cooking surface for best results.

➤ **AVAILABLE FINISHES**

White, Black or Stainless Steel

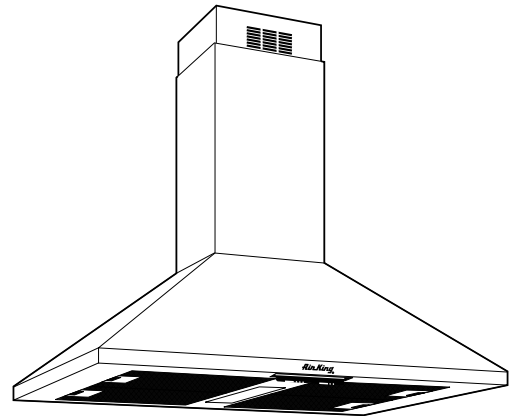

DIMENSIONS

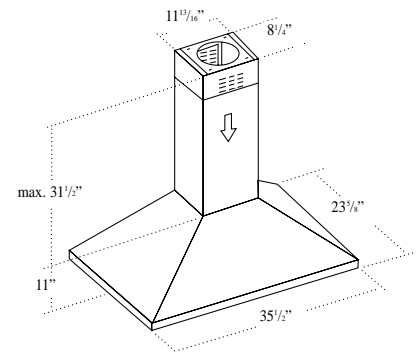

PERFORMANCE CHART											
Static pressure	0"	0.05"	0.1"	0.15"	0.2"	0.25"	0.3"	0.35"	0.4"	0.45"	0.5"
CFM	510	492	472	456	435	414	397	365	350	310	264
RPM	1876	1885	1896	1910	1965	1991	2010	2030	2058	2081	2112
WATTS	335	337	337	338	338	337	336	336	337	333	331

Air-King Barcelona Collection range hoods are tested in accordance with HVI test standard 916 for Air. The Barcelona Collection hoods are Certified and Approved by Underwriters Laboratories to UL standard 507 Electric Fans and CSA standard C22.2 No. 113 Electric Fans and Ventilators.

PROJECT							ARCHITECT				
LOCATION							ENGINEER				
CONTRACTOR							SUBMITTED BY			DATE	
FAN NUMBER	MODEL NUMBER	CFM	IN W.C.	RPM	WATTS	AMPS	SONES	QTY	OPTIONAL EQUIPMENT & REMARKS		

