

# READ AND SAVE THESE INSTRUCTIONS

READ CAREFULLY BEFORE ATTEMPTING TO ASSEMBLE, INSTALL, OPERATE OR MAINTAIN THE PRODUCT DESCRIBED. PROTECT YOURSELF AND OTHERS BY OBSERVING ALL SAFETY INFORMATION. FAILURE TO COMPLY WITH INSTRUCTIONS COULD RESULT IN PERSONAL INJURY AND/OR PROPERTY DAMAGE!

## RETAIN INSTRUCTIONS FOR FUTURE REFERENCE.

### GENERAL SAFETY INFORMATION

When using electrical appliances, basic precautions should always be followed to reduce the risk of fire, electric shock and injury to person, including the following:

1. Read all instructions before installing or using exhaust fan.
2. Use this unit only in the manner intended by the manufacturer. If you have questions, contact the manufacturer.
3. Before servicing or cleaning the unit, switch power off at service panel and lock the service disconnecting means to prevent power from being switched on accidentally. When the service disconnecting means cannot be locked, securely fasten a prominent warning device, such as a tag, to the service panel.
4. Installation work and electrical wiring must be done by qualified person(s) in accordance with all applicable codes and standards, including fire-related construction.
5. Sufficient air is needed for proper combustion and exhausting of gases through the flue (chimney) of fuel burning equipment to prevent back drafting. Follow the heating equipment manufacturer's guideline and safety standards such as those published by the National Fire Protection Association (NFPA) and the American Society for Heating, Refrigeration, and Air Conditioning Engineers (ASHRAE), and the local code authorities.
6. When cutting or drilling into wall or ceiling, do not damage electrical wiring and other hidden utilities.
7. Ducted fans must always be vented to the outdoors.
8. This unit must be grounded.
9. To avoid motor bearing damage and noisy and/or unbalanced impellers, keep drywall spray, construction dust, etc. off power unit.
10. Do not install into a ceiling thermally insulated to a value greater than R-40.
11. NEVER place a switch where it can be reached from a tub or shower.

**WARNING: TO REDUCE THE RISK OF FIRE, ELECTRIC SHOCK, DO NOT USE THIS FAN WITH ANY SOLID-STATE SPEED CONTROL DEVICE.**

**WARNING: DO NOT INSTALL OVER A TUB OR MOUNT IN A SHOWER STALL ENCLOSURE.**

**WARNING: DO NOT USE IN KITCHENS.**

**WARNING: THIS UNIT IS DESIGNED AND TESTED TO BE A SUPPLEMENTAL HEATER FOR USE WITH A TIMER OR A SWITCH. IT IS NOT INTENDED TO BE USED AS THE PRIMARY SOURCE OF HEAT AND CONTROLLED BY A THERMOSTAT.**

**CAUTION: FOR GENERAL VENTILATING USE ONLY. DO NOT USE TO EXHAUST HAZARDOUS OR EXPLOSIVE MATERIALS AND VAPORS.**

## INSTALLATION INSTRUCTIONS

**CAUTION: MAKE SURE POWER IS SWITCHED OFF AT SERVICE PANEL BEFORE STARTING INSTALLATION.**

### SECTION 1

#### Preparing the Unit

1. Unpack fan from the carton and confirm that all pieces are present. In addition to the unit you should have:
  - 1 - Grill with Light Lens
  - 4 - Mounting Rails
  - 1 - Instruction/Safety Sheet
2. Remove the two hex nuts holding the light reflector in place. Keep the reflector and nuts in the carton until needed so they do not get damaged or lost. **(Figure 1).**

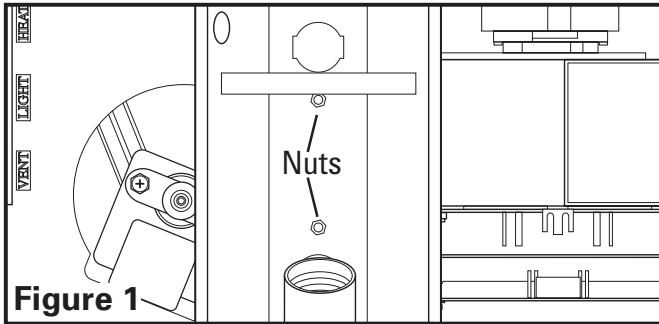

3. Remove the fan's venturi assembly, which is secured in place with one screw through the venturi **(Figure 2)**. Keep the venturi assembly and the grill in the carton until needed so they do not get damaged or lost.

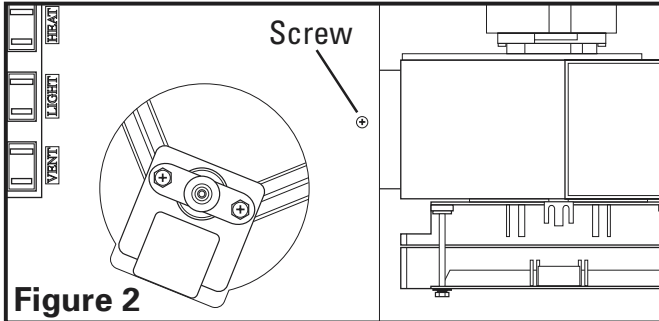

**WARNING: DO NOT INSTALL OVER A TUB OR MOUNT IN A SHOWER STALL ENCLOSURE.**

4. Choose the location for your unit. To ensure the best air and sound performance, it is recommended that the length of ducting and the number of elbows be kept to a minimum, and that insulated hard ducting be used. Larger duct sizes will reduce noise and airflow restrictions. This fan will require at least 7" of clearance in the ceiling, and will mount through drywall up to 3/4" thick. The fan mounts between 16" on center joists using the 4 provided mounting rails.
5. Remove the electrical knockouts using a straight-blade screw driver **(Figure 3)**.

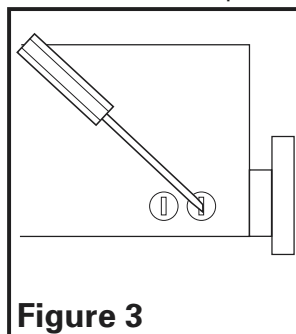

### SECTION 2

#### New Construction

1. Install the rails on the housing and position the housing next to the joist. Line up housing so it will be flush with the finished ceiling. Secure the ends of the rails with screws or nails (not included) to the joists and slide housing into final position **(Figure 4)**.

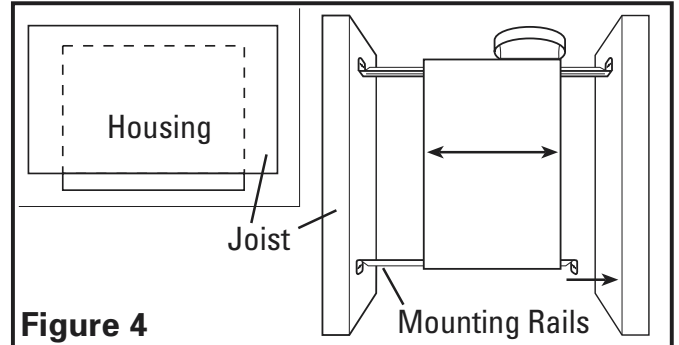

### SECTION 3

#### Existing Construction

1. Set housing in position between the joist and trace an outline onto the ceiling material **(Figure 5)**. Set housing aside and cut opening, being careful not to cut or damage any electrical or other hidden utilities. Install the rails on the housing and position the housing in the previously cut hole so that it is flush with the finished ceiling. Secure the ends of the rails to the joists with screws or nails (not provided) to ensure proper installation **(Figure 4)**.

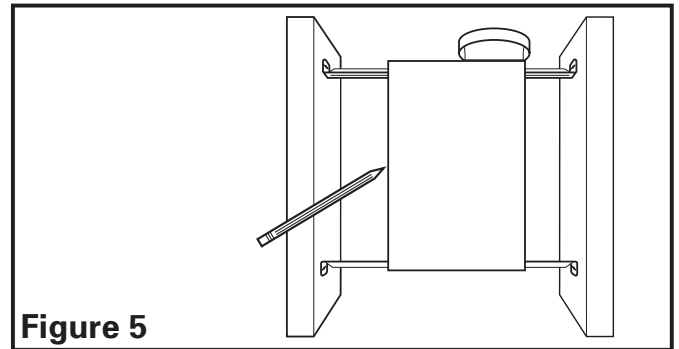

### SECTION 4

#### Ducting

**CAUTION: ALL DUCTING MUST COMPLY WITH LOCAL AND NATIONAL BUILDING CODES.**

1. Remove any tape that might be holding the damper in place. Connect the ducting to the fan's duct collar **(Figure 6)** and secure in place using tape or screw clamp. Always duct the fan to the outside through a wall or roof cap.

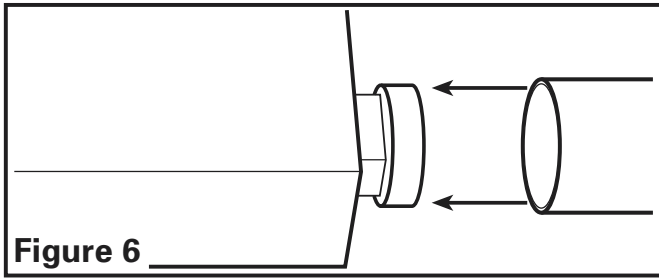

Figure 6

## SECTION 5

### Wiring

**CAUTION: MAKE SURE POWER IS SWITCHED OFF AT SERVICE PANEL BEFORE STARTING INSTALLATION.**

**WARNING: THIS UNIT MUST BE WIRED ON A SEPARATE 15 AMP CIRCUIT.**

**WARNING: USE APPROPRIATELY SIZED COPPER CONDUCTORS ONLY RATED FOR AT LEAST 75°C.**

**CAUTION: ALL ELECTRICAL CONNECTIONS MUST BE MADE IN ACCORDANCE WITH LOCAL CODES, ORDINANCES, OR NATIONAL ELECTRICAL CODE. IF YOU ARE UNFAMILIAR WITH METHODS OF INSTALLING ELECTRICAL WIRING, SECURE THE SERVICES OF A QUALIFIED ELECTRICIAN.**

1. Run wiring from wall switches carrying the appropriate rating. One neutral (white), one ground (green or bare copper), and three hot (red, blue, and yellow leads connected to the switch, one for each function). Secure the electrical wires to the housing with an approved electrical connector. Make sure you leave enough wiring in the box to make the connection to the fan's receptacles.
2. Connect the White wire from the house to the three White wires from the fan. Connect one Hot (Blue) wire from the wall switch to the Blue wire from the fan (this is the fan control). Connect second Hot (Red) wire from the wall switch to the Red wire from the fan (this is the heat control). Connect the third Hot (Yellow) wire from the wall switch to the Yellow wire from the fan (this is the light control). Connect the ground wire from the house to the Green wire from the fan (Figure 7). Use approved methods for all connections.

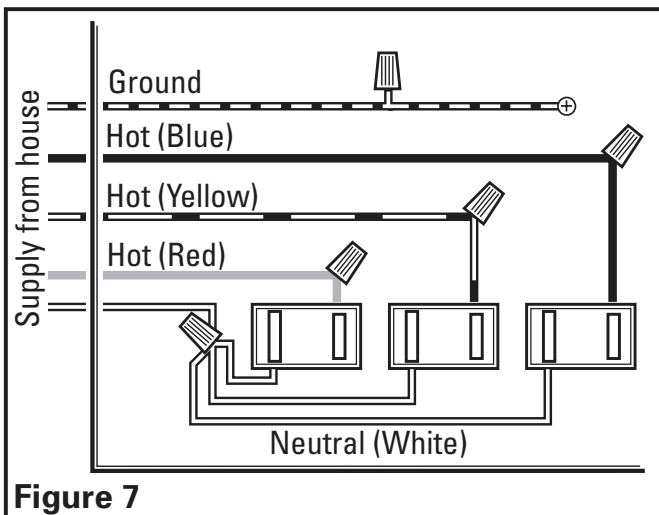

Figure 7

## SECTION 6

### Completing the Installation

1. Reinstall the fan's venturi by holding it at approximately a 45 degree angle, hook the two tabs on the venturi into the slots on the housing and secure in place by tightening the venturi screw. Rotate the blower wheel by hand to ensure it spins freely (Figure 8).

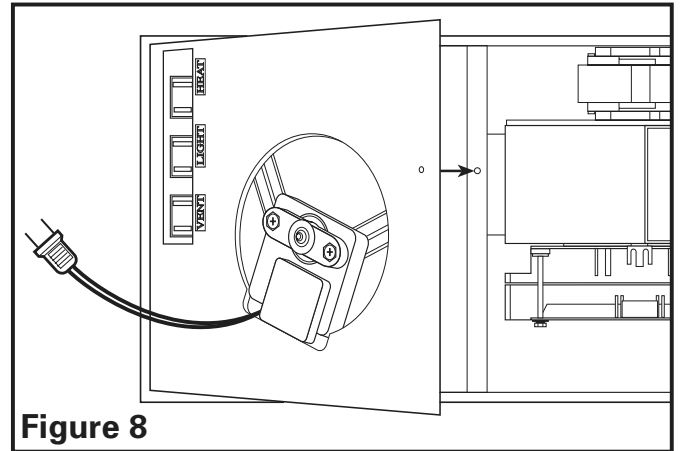

Figure 8

2. Insert the plug from the heating unit into the receptacle marked "HEAT", and the plug from the fan into the receptacle marked "VENT" (Figure 9).

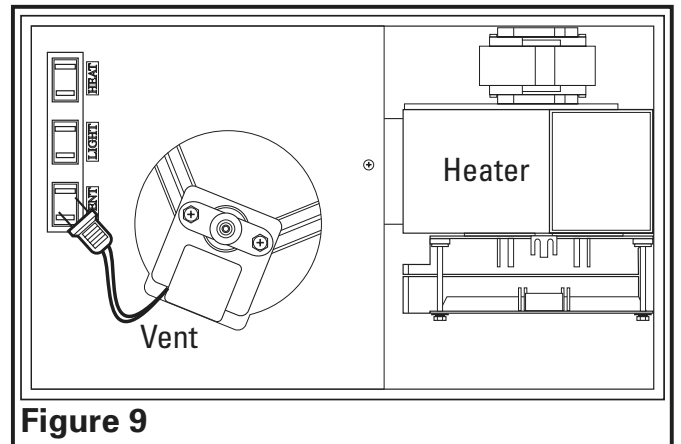

Figure 9

3. Remove grill from carton and open light lens area by pushing in on the two tabs of the light lens and pulling outward from lens. The lens will swing open on the connector bars. DO NOT remove the lens from the grill (Figure 10).

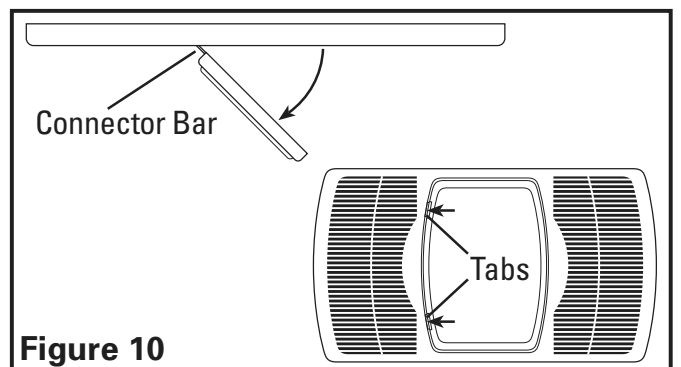
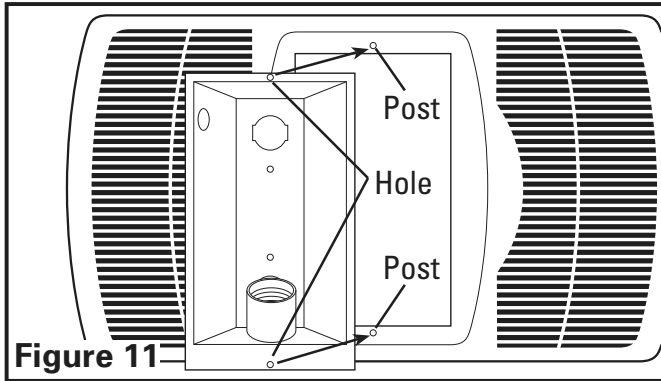

Figure 10

- Install light reflector into grill by lining up the posts on grill with the holes in light reflector (**Figure 11**). Raise light reflector and grill up to housing and insert plug from light into receptacle marked "LIGHT" (**Figure 9**).



**Figure 11**

- Attach light reflector in place with the two nuts removed during *Step 2* in **SECTION 1 Preparing the Unit** so grill fits snugly against ceiling (**Figure 12**).

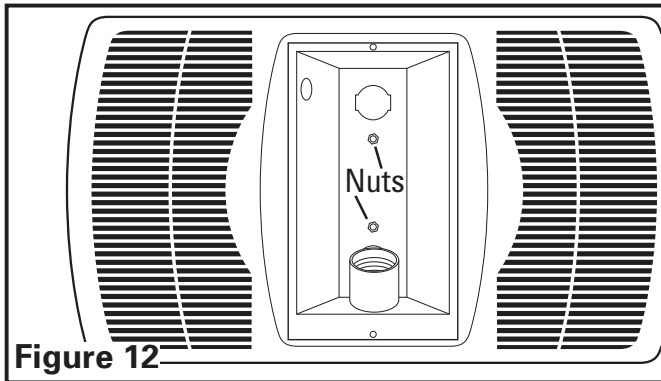

**Figure 12**

**CAUTION: FAILURE TO SECURE THE REFLECTOR SCREWS MAY RESULT IN A RATTLING OR HUMMING NOISE.**

- Install a 100 watt maximum, type A19 medium base incandescent bulb (not included).
- Close the light lens and secure in place by swinging back into position and snapping the tabs in place (**Figure 13**).

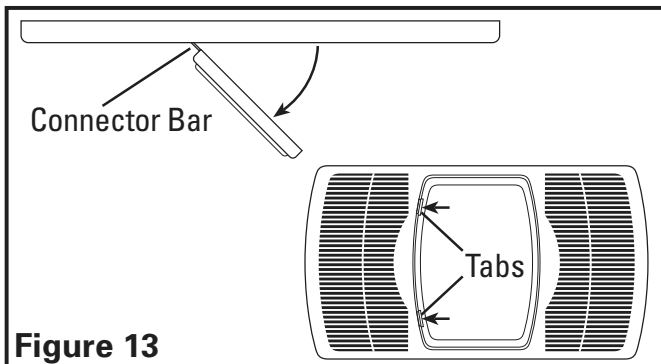

**Figure 13**

- Restore power and test your installation.

## SECTION 7

### Use and Care

**CAUTION: MAKE SURE POWER IS SWITCHED OFF AT SERVICE PANEL BEFORE SERVICING THE UNIT.**

- Cleaning the Grill:** Reverse the instructions in **Section 6 Completing the Installation** to remove grill. Use a mild detergent, such as dishwashing liquid, and dry with a soft cloth. NEVER USE ANY ABRASIVE PADS OR SCOURING POWDERS. Completely dry grill before reinstalling. Refer to instructions in **Section 6 Completing the Installation**, to reinstall grill.
- Cleaning the Fan Assembly:** Wipe all parts with a dry cloth or gently vacuum the fan. NEVER IMMERSE ELECTRICAL PARTS IN WATER.

**CAUTION: ALLOW BULB TO COOL BEFORE REPLACING.**

- Changing the Light Bulb:** Disconnect power to the unit. Open light lens by pushing in on the two tabs of light lens and pulling outward from lens. The lens will swing open on the connector bars. DO NOT remove the lens from the grill (**Figure 14**).
  - Unscrew bulb from lamp holder and replace with a 100 watt maximum, type A19 medium base incandescent bulb. Refer to instructions in **Section 6 Completing the Installation**, to reinstall grill.

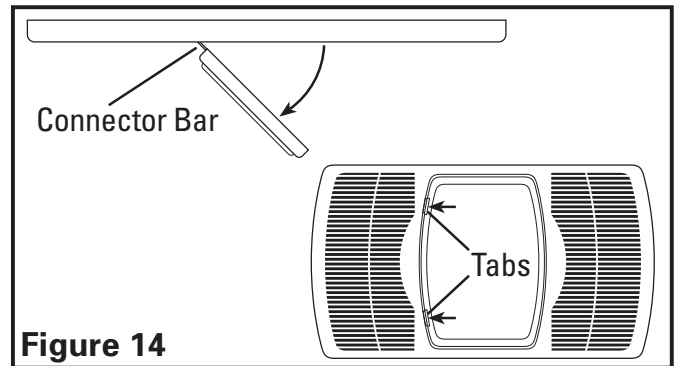

**Figure 14**

## Troubleshooting Guide

Trouble	Probable Cause	Suggested Remedy
1. Fan does not operate when the switch is on.	1a. A fuse may be blown or a circuit tripped. 1b. Connector plug from motor is not plugged in.  1c. Wiring is not connected properly. 1d. Motor has stopped operating.	1a. Replace fuse or reset circuit breaker. 1b. Turn off power to unit. Remove Grill and plug motor into receptacle in housing. Restore power to unit. 1c. Turn off power to unit. Check that all wires are connected. 1d. Replace motor.
2. Fan is operating, but air moves slower than normal.	2. Obstruction in the exhaust ducting.	2. Check for any obstructions in the ducting. The most common are bird nests in the roof cap or wall cap where the fan exhausts to the outside.
3. Fan is operating louder than normal.	3a. Motor is loose.  3b. Fan blade is hitting housing of unit.	3a. Turn off power to unit. Remove grill and check that all screws are fully tightened. Restore power to unit. 3b. Call your dealer for service.
4. Heater stopped operating.	4. Thermal Cut Out switch has tripped.	4. Turning heater off and allowing to cool will reset the heater unit.

### LIMITED WARRANTY

All products manufactured by Air King Limited are warranted for one year from the date of purchase against defects in workmanship and/or material. In addition, all ventilating/exhaust fans, heaters, combination fan lights and/or heaters, and range hoods are guaranteed for five years from the date of purchase against defects in workmanship and/or material.

This warranty does not cover any labor or shipping costs or the cost of replacement components as part of routine maintenance such as: range hood grease filters, charcoal filters or combination charcoal/grease filters; replacement light bulbs in range hoods or bathroom fan/light/bulb heater combinations. As well, any damage or failure caused by abuse, misuse, abnormal usage, faulty installation, or improper maintenance will not be covered by this warranty.

In order to make a claim on this warranty, you must be the original consumer of the product. You will be required to present to Air King the original bill of sale showing: date of purchase, place of purchase and model purchased. Failure to meet these requirements will void your warranty.

Air King will not be held responsible for any bodily injury or damages to personal property or real estate whether caused directly or indirectly by the product. Some states and provinces do not allow the exclusion or limitation of incidental or consequential damages and some states do not allow limitations on how long an implied warranty lasts, so these exclusions or limitations may not apply to you. This warranty gives you specific legal rights and you may have other rights which vary from state to state and province to province.

# REPLACEMENT PARTS DIAGRAM

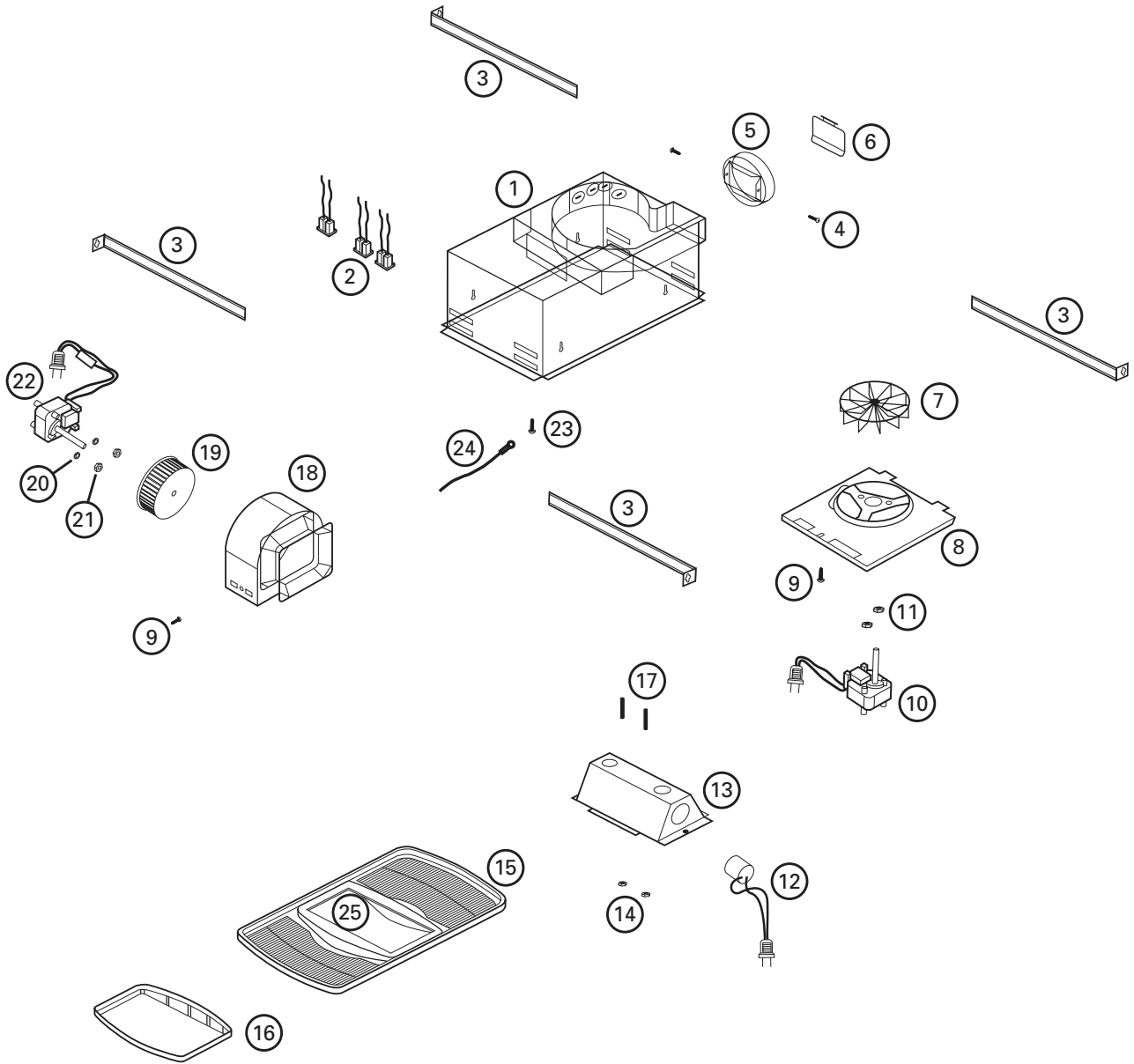

#	Qty.	Description	Replacement Part #
1	1	Fan Housing	5S3402073
2	3	Receptacle	5S3402053
3	4	Mounting Rails	5S1299002
4	2	Collar Screw	5S3402040
5	1	Collar	5S3402041
6	1	Damper	5S3402042
7	1	Impeller - Vent	5S3402074
8	1	Motor Plate	5S3402075
9	1	#8 Screw	5S1999004
10	1	Motor	5S2201003
11	2	Hex Nut	5S1999006
12	1	Lamp Holder	5S3402054
13	1	Reflector	5S3402055

#	Qty.	Description	Replacement Part #
14	2	Reflector Hex Nuts	5S1999019
15	1	Grill	5S3402056
16	1	Glass Lens	5S3402058
17	2	8-32 x 2-1/2" Mounting Posts	5S3402098
18	1	Heater Blower Housing	5S3402076
19	1	Heater Blower Wheel	5S3402077
20	2	Motor Lock Washer	5S3402049
21	2	Motor Hex Nut	5S3402050
22	1	Heater Motor	5S3402060
23	1	#10 Ground Screw	5S1999002
24	1	14 ga Ground Wire	5S1999003
25	1	Lens Frame	5S3402057